

Instructions - Parts List



55 GALLON (200 LITER) DRUM SIZE

239857 Supply Module

308769E

EN

**Includes elevator, stainless steel drum cover,
and back-geared agitator**

100 psi (0.7 MPa, 7 bar) Maximum Air Input Pressure

This module fits the following pump modules:

Part No. 232078

SST 3:1 President Module

Part No. 232079

CST 3:1 President Module

Part No. 232081

SST 3:1 President Module

Part No. 232080

SST Husky 1040 Module

Part No. 232082

SST Husky 1040 Module

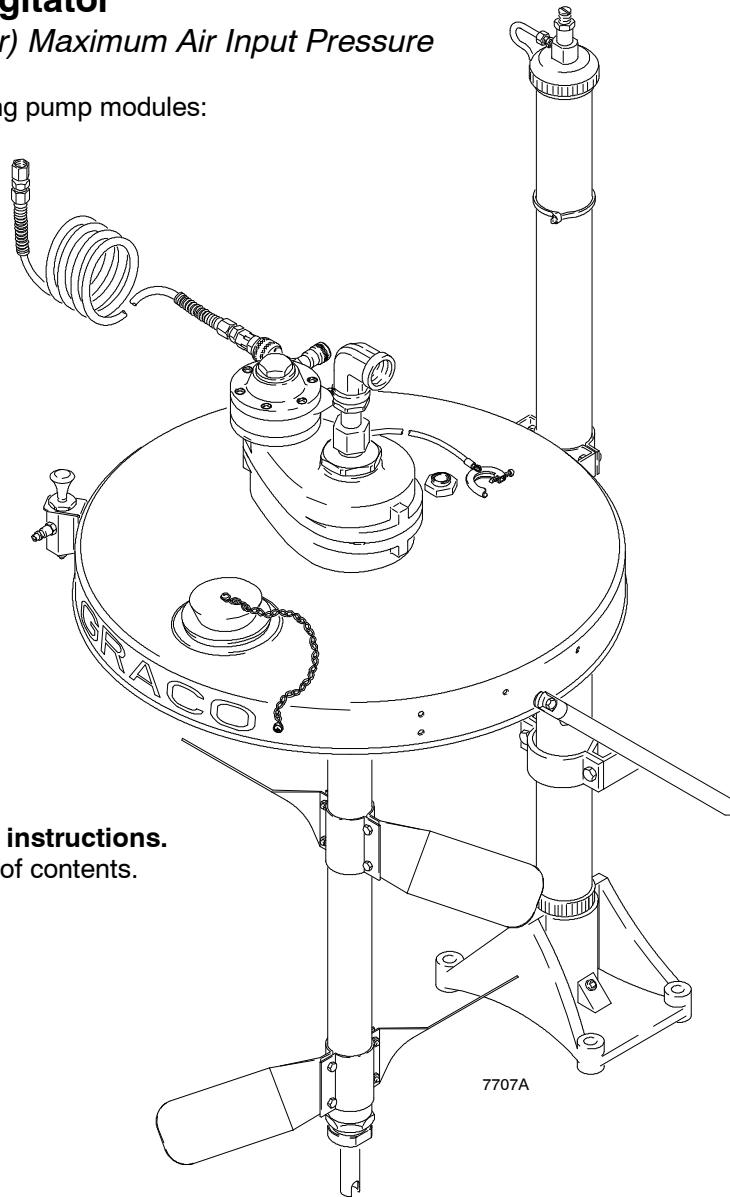

Read warnings and instructions.

See page 2 for table of contents.

PROVEN QUALITY. LEADING TECHNOLOGY.



2575



II 1/2 G T6

ITS03ATEX11251

Table of Contents

Warnings	2
Installation	5
Operation	10
Parts	12
Technical Data	14
Dimensions	14
Mounting Hole Layout	15
Graco Warranty	16
Graco Information	16

Symbols

Warning Symbol



This symbol alerts you to the possibility of serious injury or death if you do not follow the instructions.

Caution Symbol



This symbol alerts you to the possibility of damage to or destruction of equipment if you do not follow the instructions.

WARNING



INSTRUCTIONS

EQUIPMENT MISUSE HAZARD

Equipment misuse can cause the equipment to rupture or malfunction and result in serious injury.

- This equipment is for professional use only.
- Read all instruction manuals, tags, and labels before operating the equipment.
- Use the equipment only for its intended purpose. If you are uncertain about usage, call your Graco distributor.
- Do not alter or modify this equipment. Use only genuine Graco parts and accessories.
- Check equipment daily. Repair or replace worn or damaged parts immediately.
- Do not exceed the maximum working pressure stated on the equipment or in the **Technical Data** for your equipment. Do not exceed the maximum working pressure of the lowest rated component in your system.
- Use fluids and solvents which are compatible with the equipment wetted parts. Refer to the **Technical Data** section of all equipment manuals. Read the fluid and solvent manufacturer's warnings.
- Route hoses away from traffic areas, sharp edges, moving parts, and hot surfaces. Do not expose Graco hoses to temperatures above 180°F (82°C) or below -40°F (-40°C).
- Wear hearing protection when operating this equipment.
- Do not lift pressurized equipment.
- Comply with all applicable local, state, and national fire, electrical, and safety regulations.

WARNING



FIRE AND EXPLOSION HAZARD

Improper grounding, poor ventilation, open flames or sparks can cause a hazardous condition and result in a fire or explosion and serious injury.

- Ground the equipment and the object being sprayed. Refer to **Grounding** on page 8.
- If there is any static sparking or you feel an electric shock while using this equipment, **stop spraying immediately**. Do not use the equipment until you identify and correct the problem.
- Provide fresh air ventilation to avoid the buildup of flammable fumes from solvents or the fluid being sprayed.
- Keep the spray area free of debris, including solvent, rags, and gasoline.
- Electrically disconnect all equipment in the spray area.
- Extinguish all open flames or pilot lights in the spray area.
- Do not smoke in the spray area.
- Do not turn on or off any light switch in the spray area while operating or if fumes are present.
- Do not operate a gasoline engine in the spray area.



TOXIC FLUID HAZARD

Hazardous fluid or toxic fumes can cause serious injury or death if splashed in the eyes or on the skin, inhaled, or swallowed.

- Know the specific hazards of the fluid you are using.
- Store hazardous fluid in an approved container. Dispose of hazardous fluid according to all local, state and national guidelines.
- Always wear protective eyewear, gloves, clothing and respirator as recommended by the fluid and solvent manufacturer.

WARNING



PRESSURIZED EQUIPMENT HAZARD

Spray from the gun, hose leaks, or ruptured components can splash fluid in the eyes or on the skin and cause serious injury.

- Do not point the gun at anyone or at any part of the body.
- Do not stop or deflect leaks with your hand, body, glove or rag.
- Follow the **Pressure Relief Procedure** on page 10 whenever you: are instructed to relieve pressure; stop spraying; clean, check, or service the equipment; and install or clean the spray tip.
- Tighten all fluid connections before operating the equipment.
- Check the hoses, tubes, and couplings daily. Replace worn, damaged, or loose parts immediately. Permanently coupled hoses cannot be repaired; replace the entire hose.



MOVING PARTS HAZARD

Moving parts, such as the air motor piston, elevator, and agitator blades, can pinch or amputate your fingers.

- Keep clear of all moving parts when starting or operating the pump.
- Keep your hands away from the elevator, pump support, drum cover, and the lip of the drum while the elevator is operating or is charged with air.
- Always shut off the agitator and disconnect the air line before you remove the agitator from the drum or check or repair any part of the agitator.
- Before servicing the equipment, follow the **Pressure Relief Procedure** on page 10 to prevent the equipment from starting unexpectedly.

Installation

WARNING



FIRE AND EXPLOSION HAZARD

Always maintain a minimum of 1 in. clearance between rotating agitator parts and container to prevent sparks from contact.

General Information

NOTE: Reference numbers and letters in parentheses in the text refer to the callouts in the figures and the parts drawing.

NOTE: Always use Genuine Graco Parts and Accessories, available from your Graco distributor. If you supply your own accessories, be sure they are adequately sized and pressure-rated for your system.

Prepare the Operator

All persons who operate the equipment must be trained in the safe, efficient operation of all system components as well as the proper handling of all fluids. All operators must thoroughly read all instruction manuals, tags, and labels before operating the equipment.

The following manuals are included with this equipment:

- 308769, Supply Module
- 306287, Elevator
- 308466, Drum Cover
- 308609, Back-Geared Agitator

Prepare the Site

Select a site with at least 9 ft (2.8 m) overhead clearance for the elevator when fully raised.

Ensure that the wall is strong enough to support the weight of the pump and accessories, fluid, hoses, and stress caused during pump operation.

Refer to Fig. 1. Bring a compressed air supply line (A) from the air compressor to the supply module location. Be sure all air hoses are properly sized and pressure-rated for your system. Use only electrically conductive hoses. The air hose should have a 3/8 npt(m) thread.

Install a bleed-type shutoff valve (B) in the air line to isolate the air line components for servicing. Install a moisture trap and drain valve (C) to help remove moisture and contaminants from the compressed air supply.

Keep the site clear of any obstacles or debris that could interfere with the operator's movement.

Have a grounded, metal pail available for use when flushing the system.

Installation

Installing the 239857 Supply Module

NOTE: Refer to Fig. 1 and to the Dimension drawing on page 14 and the Mounting Hole Layout on page 15.

1. Ensure that there is at least 9 ft (2.8 m) overhead clearance for the elevator (150) when fully raised.

WARNING

To reduce the risk of serious injury whenever you are instructed to relieve pressure, always follow the **Pressure Relief Procedure** on page 10.

2. Remove and discard the existing suction tube at the end of suction hose (H).
3. Locate the elevator (150) so the pump's suction hose (H) will reach the swivel (101) at the top of the back-gear agitator (102). The suction hose is 6 ft (1.8 m) long. Do not stretch the hose tight; let it hang as shown in Fig. 1, to assist fluid flow into the pump.
4. See page 15. Using the elevator base as a template, mark the floor. Drill four holes in the floor for 1/2 in. bolts. Make sure the bolts are long enough to prevent the elevator from tipping.
5. Connect the suction hose to the swivel outlet (101) of the agitator (102). Connect the suction hose ground wire to the ground lug on the agitator as shown on page 8.

6. Loosen the captive screw and open the quick connector (F) on the air filter/regulator/lubricator assembly (G).
7. Slide the pipe adapter (J) out of the quick connector (F). Remove and discard the pipe plug from the bottom port of the tee (K).
8. Bring the coiled hose (105) up through the large hole in the back pressure regulator's bracket (E).
9. Screw the adapter (159) at the end of the coiled hose (105) into the tee (K).
10. Slide the pipe adapter (J) into the quick connector (F), close, and tighten the captive screw.

Supplied Components

Refer to Fig. 1.

- Fluid is supplied to the pump through the **suction tube (109)**. The suction tube is installed in the shaft of the agitator (102). See Fig. 1.
- **The back-gear agitator (102)** keeps the fluid in suspension and also includes a suction tube (109) to draw fluid from a 55 gallon drum.
- **The air-operated elevator (150)** allows you to raise the drum cover and agitator from an empty drum, replace the drum, and lower the agitator into the new drum.
- **The stainless steel drum cover (114)** fits a 55 gallon (200 liter) drum.

Installation

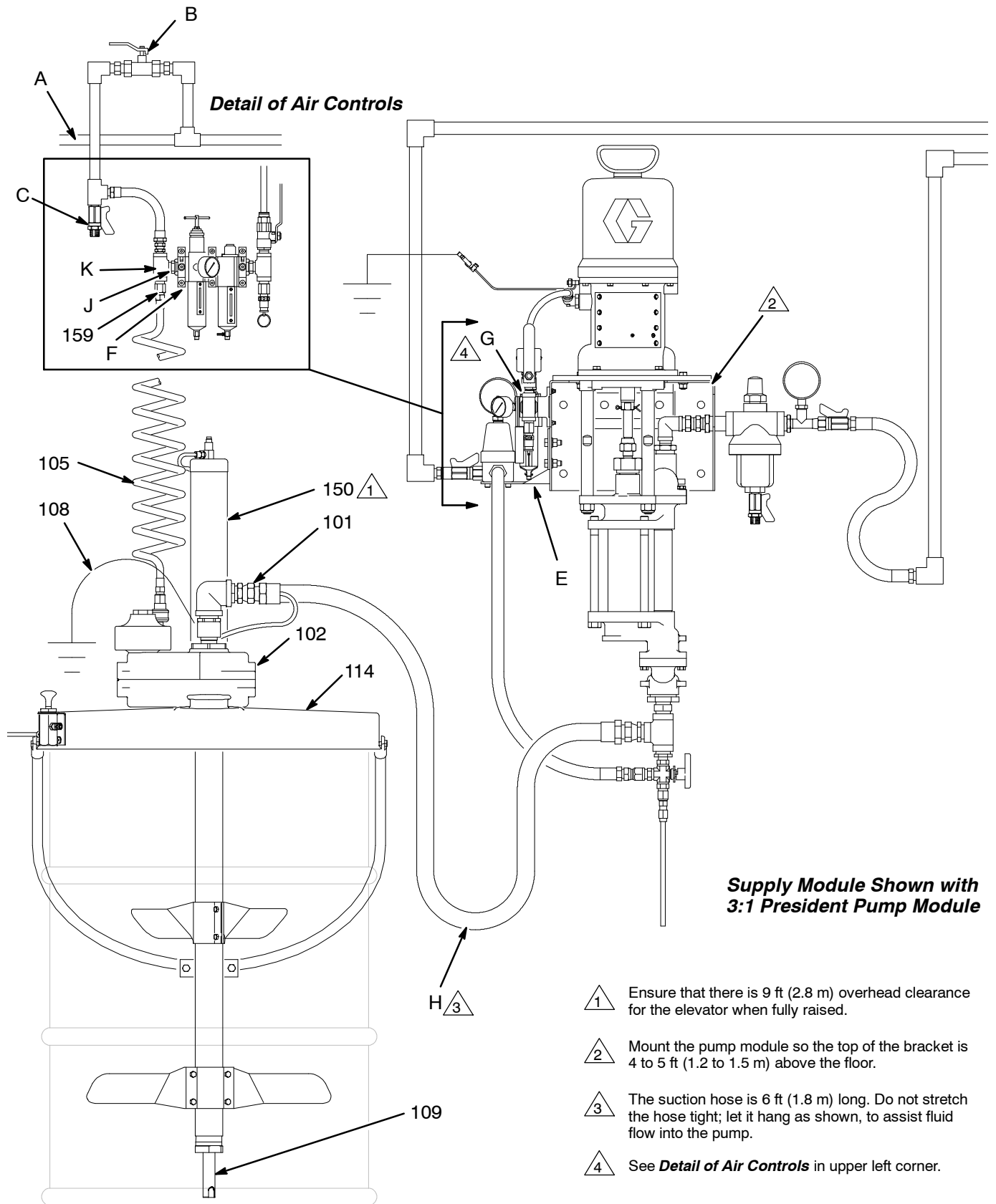

Fig. 1

7704B

Installation

Grounding

⚠ WARNING

FIRE AND EXPLOSION HAZARD
Before operating the pump, ground the system as explained below. Also read the section **FIRE AND EXPLOSION HAZARD** on page 3.

1. *Pump*: refer to the grounding instructions in your separate pump manual.
2. *Air and fluid hoses*: use only electrically conductive hoses.
3. *Air compressor*: follow manufacturer's recommendations.
4. *Spray gun*: ground through connection to a properly grounded fluid hose and pump.
5. *Agitator*: remove the ground screw (Z) and insert through the eye of the ring terminal at end of ground wire (Y). Fasten the ground screw back onto the pump and tighten securely. Connect the other end of the ground wire to a true earth ground. See Fig. 2. *To order a ground wire and clamp, order Part No. 222011.*

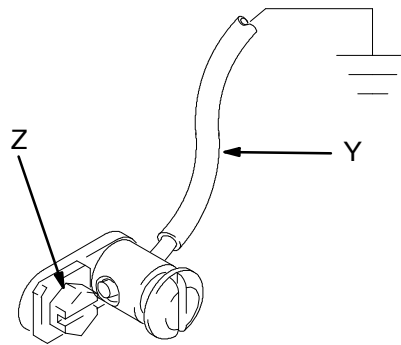

Fig. 2

T11052

6. *Suction hose*: attach the hose ground wire to the ground lug on the agitator. See Fig. 2. If you are not using an agitator, attach the wire to the fluid supply container.
7. *Fluid supply container*: follow your local code.
8. *Object being sprayed*: follow your local code.
9. *Solvent pails used when flushing*: follow your local code. Use only metal pails, which are conductive, placed on a grounded surface. Do not place the pail on a nonconductive surface, such as paper or cardboard, which interrupts the grounding continuity.
10. *To maintain grounding continuity when flushing or relieving pressure*, hold a metal part of the spray gun firmly to the side of a grounded *metal* pail, then trigger the gun.

Operation

Pressure Relief Procedure

WARNING

PRESSURIZED EQUIPMENT HAZARD

The system pressure must be manually relieved to prevent the system from starting or spraying accidentally. To reduce the risk of an injury from accidental spray from the gun, splashing fluid, or moving parts, follow the **Pressure Relief Procedure** whenever you:

- are instructed to relieve the pressure,
- stop spraying,
- check or service any of the system equipment,
- or install or clean the spray nozzle.

1. Press down the air control valve (P) button. Lower the elevator until the cover (114) rests properly on the lip of the drum. Disconnect the quick coupler (124) from the male fitting (D) on the air control valve.
2. Relieve the air and fluid pressure, following the instructions in your separate pump manual.

Elevator Operation

1. To raise the elevator (150), connect the quick coupler (124) on the end of the coiled hose (105) to the male fitting (D) on the air control valve (P). Pull up the air control valve button to raise the elevator to its full height.

WARNING



MOVING PARTS HAZARD

Moving parts can pinch or amputate your fingers. When raising or lowering the elevator, keep your fingers and hands away from the elevator (150), cover support (125), drum cover (114), and lip of the drum.

Do not remove the quick coupler (124) from the male fitting (D) until the elevator is completely lowered.

2. Position a full drum under the drum cover (114).
3. To lower the elevator (150), press down the air control valve (P) button. Lower the elevator until the cover (114) rests properly on the lip of the drum. Disconnect the quick coupler (124) from the male fitting (D).
4. Refer to manual 306287 for further elevator operating instructions.

Agitator Operation

1. Close the agitator's needle valve (L).
2. Connect the quick coupler (124) on the end of the coiled hose (105) to the male fitting (M) on the agitator (102).
3. Slowly open the needle valve (L) to start the agitator (102). Use the valve to adjust the speed. Do not operate the agitator too fast. If the fluid foams or a vortex forms on the fluid surface, reduce the speed of the agitator.
4. Refer to manual 308609 for further agitator operating instructions.

Shutdown

WARNING

To reduce the risk of serious injury whenever you are instructed to relieve pressure, always follow the **Pressure Relief Procedure** on page 10.

1. Lower the elevator (150).
2. Shut off the agitator (102).
3. Relieve the pressure.

Operation

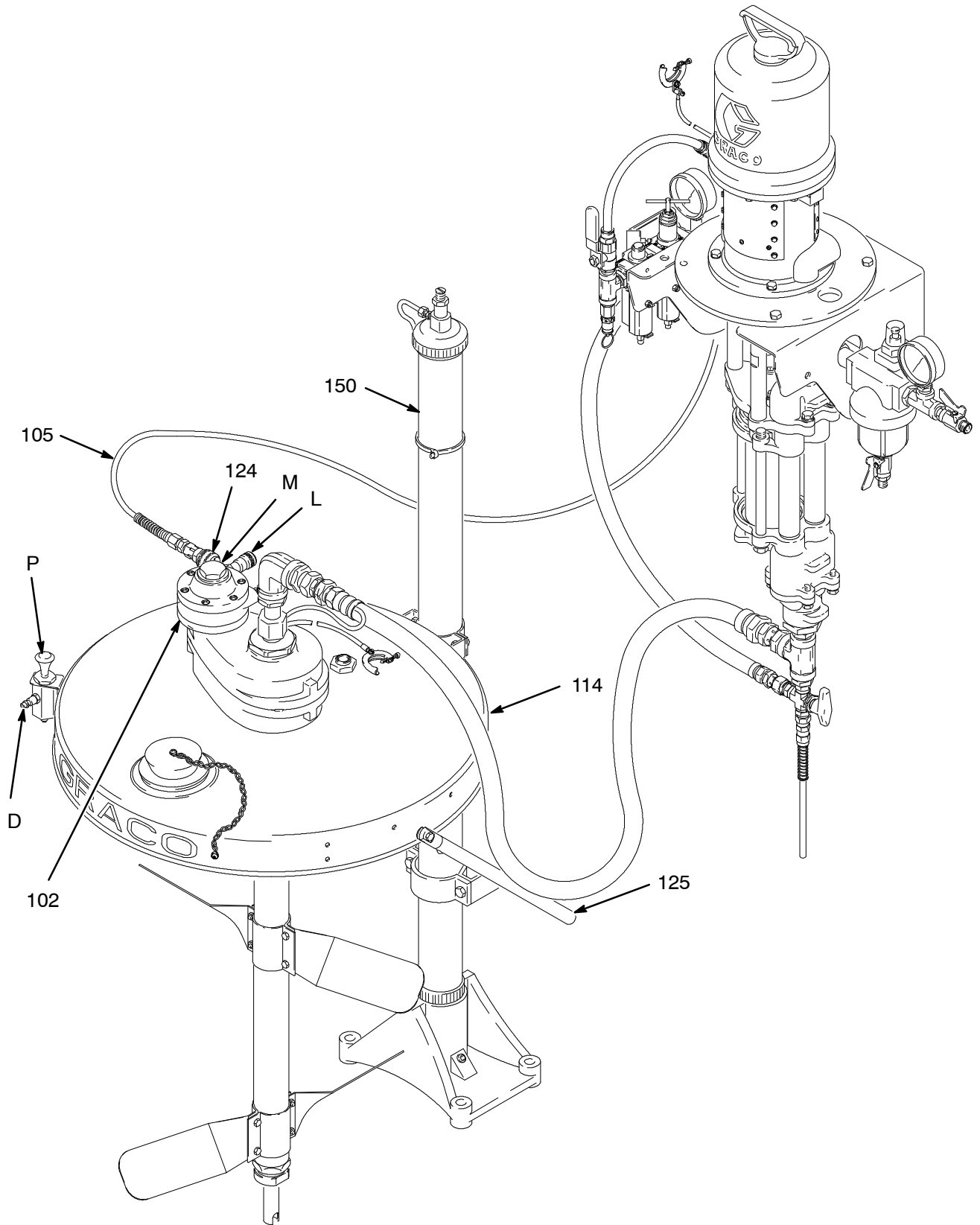
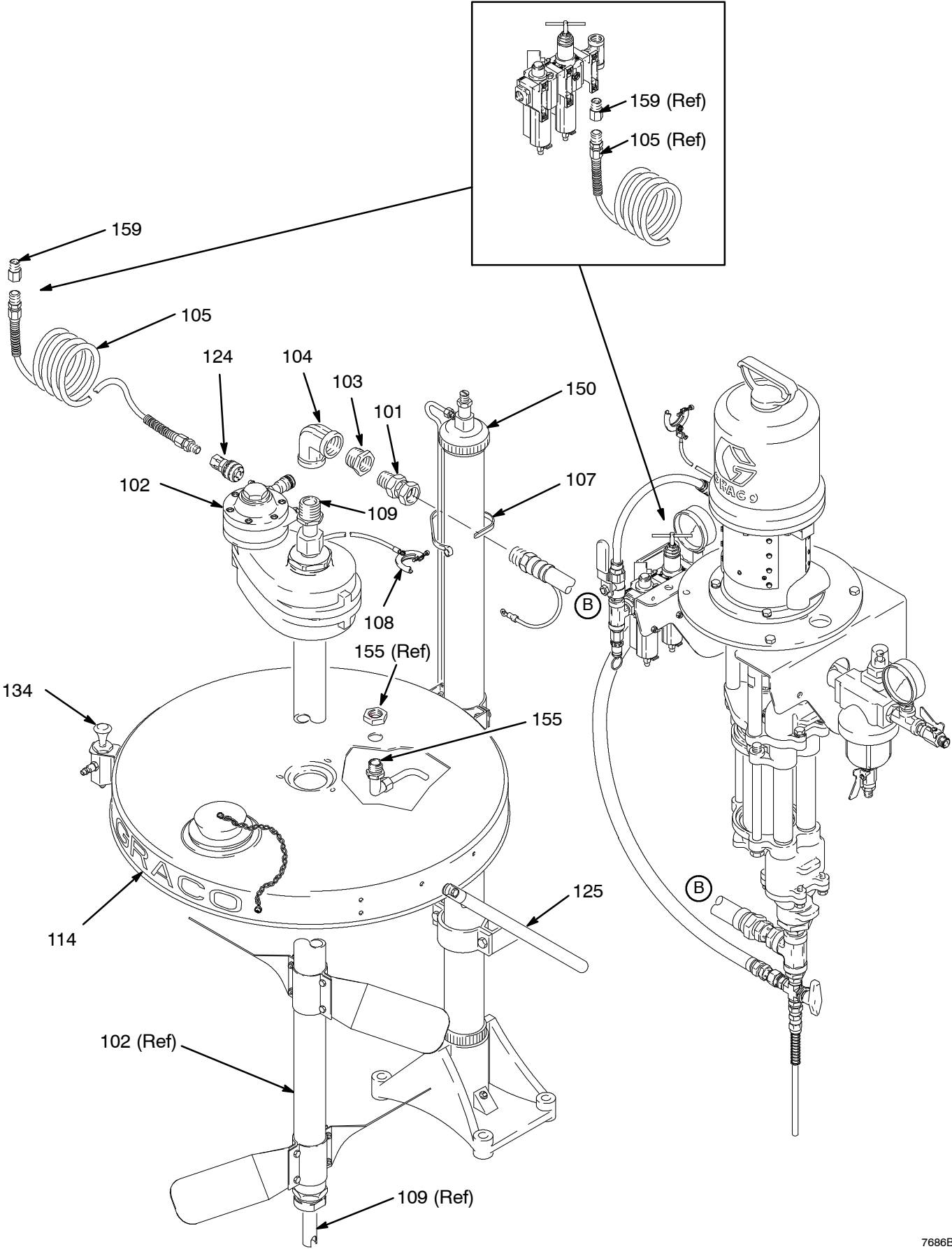

Fig. 3

7688B

Parts

Part No. 239857, Series A, Supply Module



Parts

Part No. 239857, Series A, Supply Module

Ref. No.	Description	Part No.	Qty
101	SWIVEL; sst; 3/4 npt (m x f)	112268	1
102	AGITATOR, back-gearred; <i>see manual 308609</i>	238157	1
103	BUSHING; sst; 1" npt(m) x 3/4 npt(f)	502851	1
104	ELBOW, 90°; sst; 1" npt (fbe)	500251	1
105	HOSE, air; nylon; 1/4 in. (6 mm) ID; 1/4 npt (mbe); 50 ft (15.2 m) long	205600	1
107	STRAP, tie	103546	3
108	GROUND WIRE AND CLAMP	222011	1
109	RISER TUBE KIT; <i>see manual 308609</i>	238250	1
114	COVER, drum; sst; <i>see manual 308466</i>	238283	1
124	COUPLER, quick disconnect, female	114558	1
125	ASSEMBLY, cover support; <i>see manual 306287</i>	237578	1
134	KIT, air control, elevator; <i>see manual 306287</i>	237579	1
150	ELEVATOR, drum; <i>see manual 306287</i>	204385	1
155	KIT, return tube	238884	1
159	ADAPTER; 3/8 npt(m) x 1/4 npt(f)	159841	1

Technical Data

Category	Data
Maximum air input pressure	100 psi (0.7 MPa, 7 bar)
Weight	approximately 100 lb (45 kg)
Wetted parts	<i>Back-Geared Agitator:</i> See agitator manual 308609. <i>Drum Cover:</i> Stainless Steel <i>Fluid Hoses:</i> Nylon

Dimensions

1 Ensure that there is 9 ft (2.8 m) overhead clearance for the elevator when fully raised.

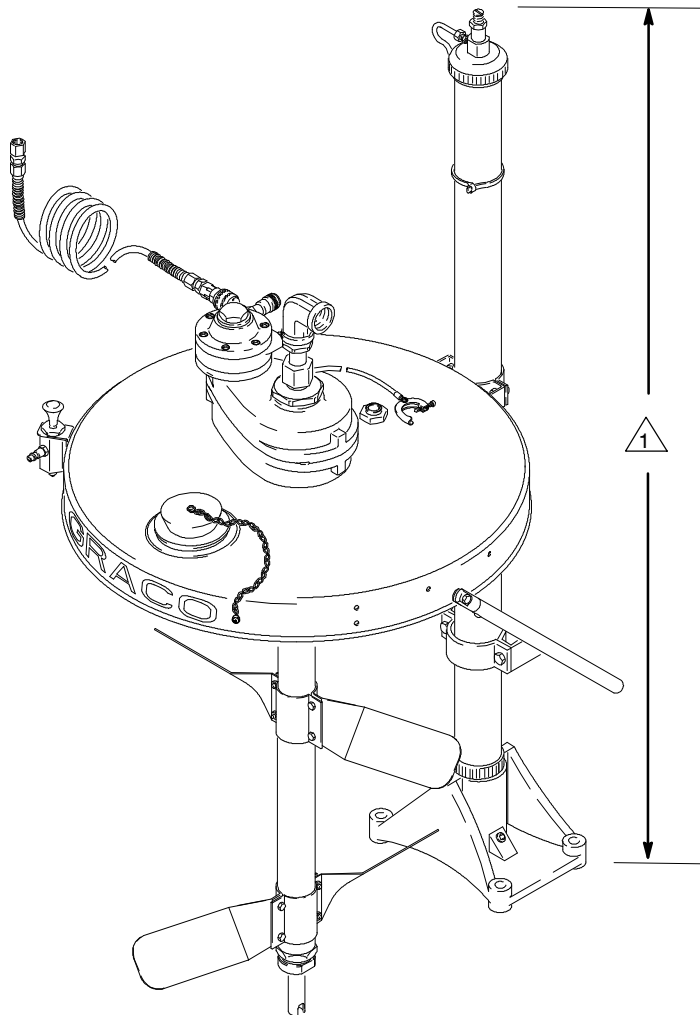

7707A

Mounting Hole Layout

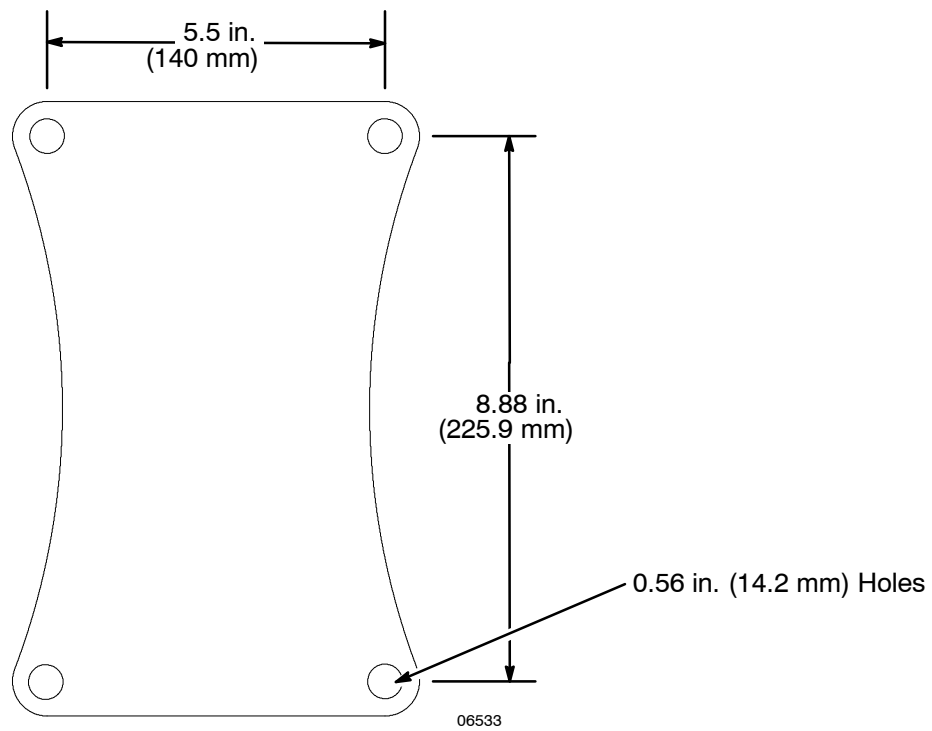

Graco Standard Warranty

Graco warrants all equipment manufactured by Graco and bearing its name to be free from defects in material and workmanship on the date of sale by an authorized Graco distributor to the original purchaser for use. With the exception of any special, extended, or limited warranty published by Graco, Graco will, for a period of twelve months from the date of sale, repair or replace any part of the equipment determined by Graco to be defective. This warranty applies only when the equipment is installed, operated and maintained in accordance with Graco's written recommendations.

This warranty does not cover, and Graco shall not be liable for general wear and tear, or any malfunction, damage or wear caused by faulty installation, misapplication, abrasion, corrosion, inadequate or improper maintenance, negligence, accident, tampering, or substitution of non-Graco component parts. Nor shall Graco be liable for malfunction, damage or wear caused by the incompatibility of Graco equipment with structures, accessories, equipment or materials not supplied by Graco, or the improper design, manufacture, installation, operation or maintenance of structures, accessories, equipment or materials not supplied by Graco.

This warranty is conditioned upon the prepaid return of the equipment claimed to be defective to an authorized Graco distributor for verification of the claimed defect. If the claimed defect is verified, Graco will repair or replace free of charge any defective parts. The equipment will be returned to the original purchaser transportation prepaid. If inspection of the equipment does not disclose any defect in material or workmanship, repairs will be made at a reasonable charge, which charges may include the costs of parts, labor, and transportation.

THIS WARRANTY IS EXCLUSIVE, AND IS IN LIEU OF ANY OTHER WARRANTIES, EXPRESS OR IMPLIED, INCLUDING BUT NOT LIMITED TO WARRANTY OF MERCHANTABILITY OR WARRANTY OF FITNESS FOR A PARTICULAR PURPOSE.

Graco's sole obligation and buyer's sole remedy for any breach of warranty shall be as set forth above. The buyer agrees that no other remedy (including, but not limited to, incidental or consequential damages for lost profits, lost sales, injury to person or property, or any other incidental or consequential loss) shall be available. Any action for breach of warranty must be brought within two (2) years of the date of sale.

Graco makes no warranty, and disclaims all implied warranties of merchantability and fitness for a particular purpose in connection with accessories, equipment, materials or components sold but not manufactured by Graco. These items sold, but not manufactured by Graco (such as electric motors, switches, hose, etc.), are subject to the warranty, if any, of their manufacturer. Graco will provide purchaser with reasonable assistance in making any claim for breach of these warranties.

In no event will Graco be liable for indirect, incidental, special or consequential damages resulting from Graco supplying equipment hereunder, or the furnishing, performance, or use of any products or other goods sold hereto, whether due to a breach of contract, breach of warranty, the negligence of Graco, or otherwise.

FOR GRACO CANADA CUSTOMERS

The parties acknowledge that they have required that the present document, as well as all documents, notices and legal proceedings entered into, given or instituted pursuant hereto or relating directly or indirectly hereto, be drawn up in English. Les parties reconnaissent avoir convenu que la rédaction du présente document sera en Anglais, ainsi que tous documents, avis et procédures judiciaires exécutés, donnés ou intentés à la suite de ou en rapport, directement ou indirectement, avec les procédures concernées.

Graco Information

TO PLACE AN ORDER, contact your Graco distributor, or call this number to identify the distributor closest to you:
1-800-328-0211 Toll Free

*All written and visual data contained in this document reflects the latest product information available at the time of publication.
Graco reserves the right to make changes at any time without notice.*

Sales Office: Minneapolis
Foreign Offices: Belgium, Canada, England, Korea, France, Germany, China, Japan

GRACO INC. P.O. BOX 1441 MINNEAPOLIS, MN 55440-1441

<http://www.graco.com>

©1998-1997 Graco Inc. 308769 Rev. E 03/2019 PRINTED IN U.S.A.