

Box Lubricator/ Lubricator Reservoir

3A3006H

EN

Lubrication reservoir used with GBL 7500 Gravity Fed or Pressure Fed Box Lubricator Pumps for dispensing non-corrosive and non-abrasive oils and lubricants. For professional use only.

Maximum Input: 1800 RPM
Drive Ratio: 118:1

Models, page 3.



Important Safety Instructions

Read all warnings and instructions in this manual before using the equipment.
Save these instructions.

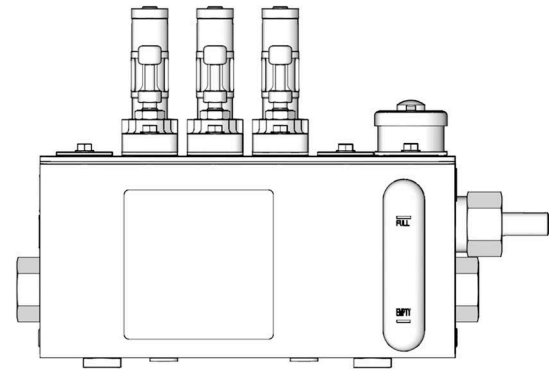

Related Manuals

Manual (English)	Description
3A2257	GBL 7500 Box Lubricator Pump and GBL Shaft Rotation/Low Level Alarm Pump

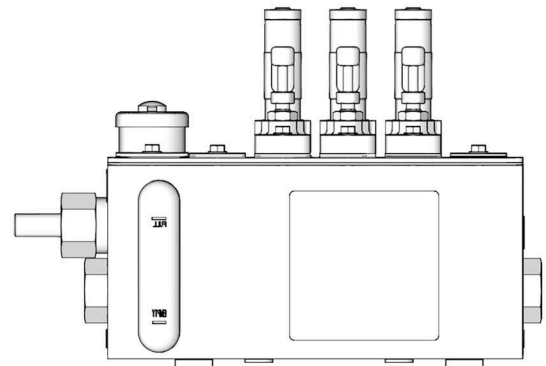





t37868a

Contents

Contents	2
Models	3
Warnings	4
Component Identification	6
Installation	7
Grounding	7
Installation Procedure	7
Drive Mechanism	7
Operation	8
Pressure Relief Procedure	8
Break In Period	8
Maintenance	9
Lube Refill/Replace	9
Recycling and Disposal	10
End of Product Life	10
Troubleshooting	11
Parts	12
Accessories	13
Pumps*	13
Other Accessories*	13
Technical Specifications	14
Reservoir and Mounting Dimensions	15
Dimensions Table	16
California Proposition 65	17
Graco Standard Warranty	18









Models

Model	Description	Pump Quantity	Maximum Working Pressure (psi)	Certification
24W633	Reservoir Assembly, 4 Pint, RH		NA	
25R513	Reservoir Assembly, 4 Pint, LH		NA	
24W634	Reservoir Assembly, 6 Pint, RH		NA	
25R514	Reservoir Assembly, 6 Pint, LH		NA	
25R555*	Box Lubricator, 4 Pint, 3/8 in. pump, RH	3	3500	 
25R559*	Box Lubricator, 4 Pint, 3/8 in. pump, LH	3	3500	
25R554*	Box Lubricator, 6 Pint, 3/8 in. pump, RH	5	3500	
25R558*	Box Lubricator, 6 Pint, 3/8 in. pump, LH	5	3500	
24W636*	Box Lubricator, 4 Pint, 1/4 in. pump, RH	3	6000	 
25R557*	Box Lubricator, 4 Pint, 1/4 in. pump, LH	3	6000	
24W635*	Box Lubricator, 6 Pint, 1/4 in. pump, RH	5	6000	
25R556*	Box Lubricator, 6 Pint, 1/4 in. pump, LH	5	6000	





*Applied protection: "k"

Warnings

The following warnings are for the setup, use, grounding, maintenance, and repair of this equipment. The exclamation point symbol alerts you to a general warning and the hazard symbols refer to procedure-specific risks. When these symbols appear in the body of this manual or on warning labels, refer back to these Warnings. Product-specific hazard symbols and warnings not covered in this section may appear throughout the body of this manual where applicable.

 <h2 style="margin: 0;">WARNING</h2>	
    	<p>SKIN INJECTION HAZARD</p> <p>High-pressure fluid from dispensing device, hose leaks, or ruptured components will pierce skin. This may look like just a cut, but it is a serious injury that can result in amputation. Get immediate surgical treatment.</p> <ul style="list-style-type: none"> • Do not point dispensing device at anyone or at any part of the body. • Do not put your hand over the fluid outlet. • Do not stop or deflect leaks with your hand, body, glove, or rag. • Follow the Pressure Relief Procedure when you stop dispensing and before cleaning, checking, or servicing equipment. • Tighten all fluid connections before operating the equipment. • Check hoses and couplings daily. Replace worn or damaged parts immediately.
 	<p>FIRE AND EXPLOSION HAZARD</p> <p>When flammable fluids are present in the work area, such as gasoline and windshield wiper fluid, be aware that flammable fumes can ignite or explode. To help prevent fire and explosion:</p> <ul style="list-style-type: none"> • Use equipment only in well-ventilated area. • Eliminate all ignition sources, such as cigarettes and portable electric lamps. • Ground all equipment in the work area. • Keep work area free of debris, including rags and spilled or open containers of solvent and gasoline. • Do not plug or unplug power cords or turn lights on or off when flammable fumes are present. • Use only grounded hoses. • Stop operation immediately if static sparking occurs or you feel a shock. Do not use equipment until you identify and correct the problem. • Keep a working fire extinguisher in the work area.

! WARNING

 	<p>EQUIPMENT MISUSE HAZARD Misuse can cause death or serious injury.</p> <ul style="list-style-type: none"> • Do not operate the unit when fatigued or under the influence of drugs or alcohol. • Do not exceed the maximum working pressure or temperature rating of the lowest rated system component. See Technical Specifications in all equipment manuals. • Use fluids and solvents that are compatible with equipment wetted parts. See Technical Specifications in all equipment manuals. Read fluid and solvent manufacturer's warnings. For complete information about your material, request Safety Data Sheets (SDSs) from distributor or retailer. • Turn off all equipment and follow the Pressure Relief Procedure when equipment is not in use. • Check equipment daily. Repair or replace worn or damaged parts immediately with genuine manufacturer's replacement parts only. • Do not alter or modify equipment. Alterations or modifications may void agency approvals and create safety hazards. • Make sure all equipment is rated and approved for the environment in which you are using it. • Use equipment only for its intended purpose. Call your distributor for information. • Route hoses and cables away from traffic areas, sharp edges, moving parts, and hot surfaces. • Do not kink or over bend hoses or use hoses to pull equipment. • Keep children and animals away from work area. • Comply with all applicable safety regulations.
 	<p>MOVING PARTS HAZARD Moving parts can pinch, cut or amputate fingers and other body parts.</p> <ul style="list-style-type: none"> • Keep clear of moving parts. • Do not operate equipment with protective guards or covers removed. • Equipment can start without warning. Before checking, moving, or servicing equipment, follow the Pressure Relief Procedure and disconnect all power sources.
	<p>PERSONAL PROTECTIVE EQUIPMENT Wear appropriate protective equipment when in the work area to help prevent serious injury, including eye injury, hearing loss, inhalation of toxic fumes, and burns. Protective equipment includes but is not limited to:</p> <ul style="list-style-type: none"> • Protective eyewear, and hearing protection. • Respirators, protective clothing, and gloves as recommended by the fluid and solvent manufacturer.

Component Identification

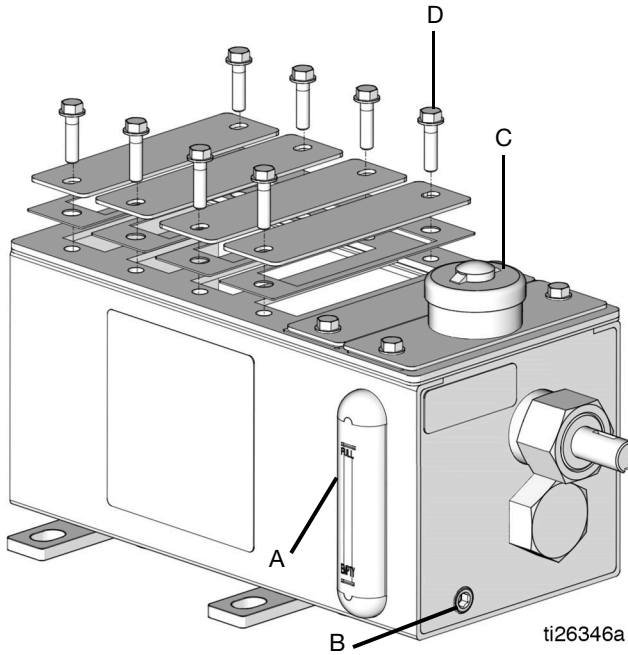

FIG. 1:



Key:

- A Sight Glass
- B Drain Plug
- C Fill Cover
- D Pump Mounting Screws

The GBL 7500 Box Lubricator Pump and GBL Alarm Pump are available from Graco. See **Accessories**, page 13 for information about the pump models.

Installation



Grounding

				
<p>The equipment must be grounded to reduce the risk of static sparking. Static sparking can cause fumes to ignite or explode. Grounding provides an escape wire for the electric current.</p>				

Securely mount and ground the lubricator before operation.

Installation Procedure

The uppercase letters used in the following instructions refer to **Component Identification** (FIG. 1), page 6.

				
<p>Mount the reservoir securely so is unable to move during operation. Failure to do so could result in injury or equipment damage.</p>				

1. Mount the reservoir on a sturdy, flat surface that can support the weight of the reservoir when filled with lubricant. Install so that the Fill Cover (C) and the Drain Plug (B) are easily accessible after installation, and that the Sight Glass (A) is visible.

NOTE: See **Reservoir and Mounting Dimensions** section, page 15, for mounting hole layout.

2. Install the mounting brackets and tighten securely.
3. Install the GBL 7500 pump(s) into the box. Tighten the Pump Mounting Screws (torque 110 in-lb +/- 10 in-lb, 12.43 N•m +/- 1.13 N•m).



NOTE: Up to six pumps may be installed. Refer to the GBL 7500 manual for output adjustment and pump information.

4. Remove the Fill Cover (C) and fill the reservoir with clean, filtered fluid until it reaches the FULL line on the Sight Glass (A).

NOTE:

- Filter the oil with a minimum 25 micron strainer. Depending upon machine requirements, it may be necessary to maintain a higher cleanliness level.
- A blank plate is provided to install over any unused pump stations.
- Refer to the pump instruction manual for installation and priming instructions. See **Parts**, page 12 for Graco pump model information.

Drive Mechanism

				
<p>Moving parts can pinch, cut or amputate fingers and other body parts.</p> <ul style="list-style-type: none"> • Install protective guards around all drive components. • Do not operate equipment if the protective guards are not installed. 				

NOTE: A 1/2 in. diameter shaft is included to connect the lubricator to a rotary power source.

NOTICE
<p>To avoid damage to the box lubricator, do not exceed the maximum recommended speed of the lubricator input shaft of 1800 rpm.</p>

Operation

The letters used in the following instructions refer to **Component Identification** (FIG. 1), page 6.

Pressure Relief Procedure



Follow the Pressure Relief Procedure whenever you see this symbol.

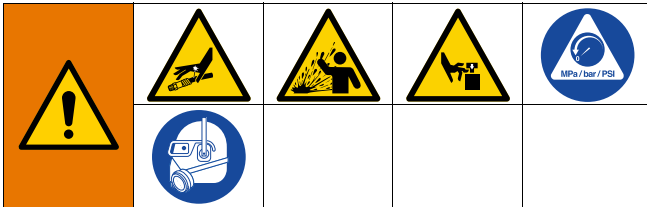

This equipment stays pressurized until pressure is manually relieved. To help prevent serious injury from pressurized fluid, such as skin injection, splashing fluid and moving parts, follow the Pressure Relief Procedure in your pump manual when you stop dispensing and before cleaning, checking, or servicing the equipment.

Break In Period

Fill the gear box to the FULL line on the Sight Glass (A) with SAE 30 to SAE 40 weight gear lube. Run normally, and change the gear lube after the two week break in period (FIG. 2).

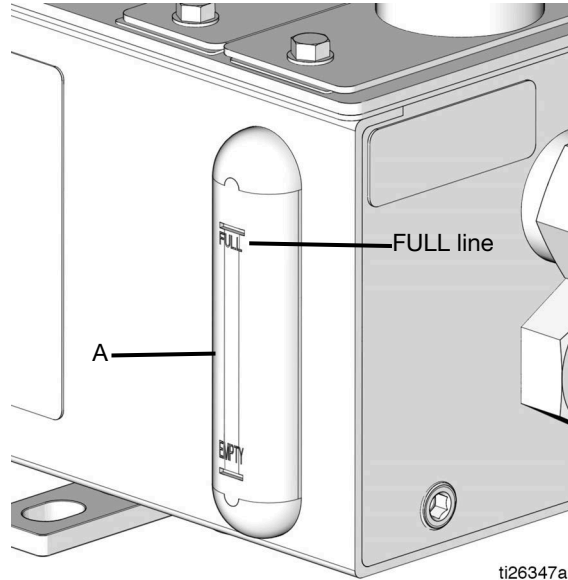



FIG. 2:

Maintenance

				
<p>Moving parts can pinch, cut or amputate fingers and other body parts.</p> <p>Follow the Pressure Relief Procedure from your pump manual, before performing maintenance of the pump.</p>				

1. If equipped, the lubricator operation can be checked by observing the drip tube located within the sight glass well of the pump.
 - If the correct pumping rate is maintained, no servicing is required other than periodic replenishment of the reservoir.
 - If the sight glass well pumps dry or no flow is observed, refer to **Troubleshooting**, page 11.
2. Inspect the lubricator for worn or damaged components, and replace as needed.
3. Clean the lubricator periodically to eliminate any contamination to the oil.
 - a. Remove the Drain Plug (B) (FIG. 3) and drain the reservoir. Dispose of the oil according to all applicable regulations.
 - b. Remove the pumps.
 - c. Clean the pumps and reservoir by brushing loose all foreign matter, dipping in solvent and blowing dry using compressed air.
 - d. Reinstall the pumps and tighten (torque 110 in-lb +/- 10 in.lb, 12.43 N•m +/- 1.13 N•m).
 - e. Apply thread sealant (user supplied) to the Drain Plug (B), reinstall and tighten (torque 35 in-lb +/- 5 in-lb, 3.95 N•m +/- 0.6 N•m).
 - f. Fill the reservoir, see **Lube Refill/Replace**, page 9.

Lube Refill/Replace

When needed, refill the reservoir with clean filtered lubricant until it reaches the FULL line on the Sight Glass (A) (FIG. 3).

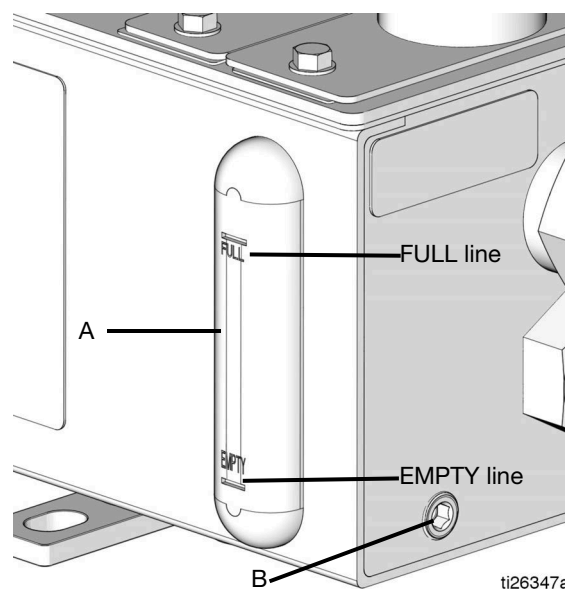

FIG. 3:

Monitor the fluid level using the sight level gauge on the reservoir. The oil level should not be allowed to drop to or below the EMPTY line (FIG. 3), indicating an empty reservoir.

Monitor the gearbox lubricant level regularly to ensure proper lubrication.

Change the lubricant annually.

Recycling and Disposal

End of Product Life

At the end of the product's useful life, dismantle and recycle it in a responsible manner.

- Perform the **Pressure Relief Procedure**.
- Drain and dispose of fluids according to applicable regulations. Refer to the material manufacturer's Safety Data Sheet.
- Deliver remaining product to a recycling facility.

Troubleshooting





Follow the **Pressure Relief Procedure** in your pump manual before checking or repairing the lubricator.

Check all possible problems and causes before disassembling.

Problem	Cause	Solution
The lube level is not visible in the sight glass.	Low oil level in reservoir.	Add oil. See Lube Refill/Replace , page 9. Check the Drain Plug and tighten, if needed.
No flow from pump outlets.	The camshaft is not rotating because the rotary power source is defective.	Repair/replace the rotary power source.
	The camshaft is broken.	Replace the lubricator box.
	There is a pump issue.	Refer to the Troubleshooting section of the pump instruction manual.
Leaking from under pump.	The gasket is defective.	Replace the gasket.
Leaking from reservoir drain plug.	Insufficient thread sealant.	Clean and replace the thread sealant (user supplied).

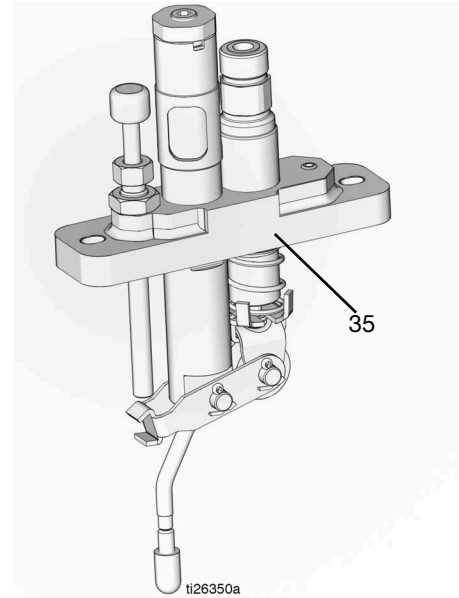
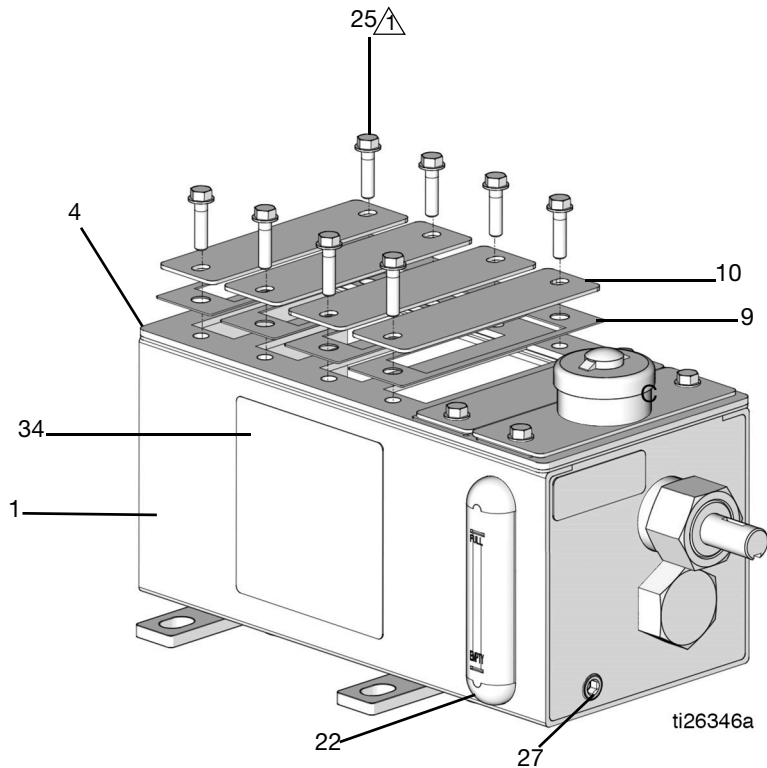
Parts



 Torque to 110 in. lbs ± 10 in. lbs.

Ref.	Part	Description	Qty.	Ref.	Part	Description	Qty.
1	17C573	RESERVOIR, 4 pt, models 24W633, 24W636 AND 25R555	1	21	556715	GASKET, level sight glass (not shown)	1
	132563	RESERVOIR, 4 pt, models 25R513, 25R557, and 25R559	1	22	556697	SIGHT GLASS, level	1
	17C574	RESERVOIR, 6 pt, models 24W634, 24W635 AND 25R554	1	25	119426	SCREW, machine, hex washer head, models 24W633 and 24W636	10
	132656	RESERVOIR, 6 pt, models 25R514, 25R556, and 25R558	1			SCREW, machine, hex washer head, models 24W634 and 24W635	14
4	16Y559	COVER, models 24W633 and 24W636	1	27	557391	PLUG, dry seal, 1/4 NPTF	2
	17D148	COVER, models 24W634 and 24W635	1	34▲	16G243	LABEL, safety, warning, injection, fire, and explosion	1
	5	16Y558 GASKET, cover (not shown) models 24W633 and 24W636	1	35◆	24J392	PUMP, GBL, 7500, suction, models 24W635 and 25R556	5
	17D149	GASKET, cover (not shown) models 24W634 and 24W635	1			PUMP, GBL, 7500, suction, models 24W636 and 25R557	3
9	556732	GASKET, pump, models 24W633 and 24W636	5		24J393	PUMP, GBL, 7500, suction, models 25R554 and 25R558	5
		GASKET, pump, models 24W634 and 24W635	7			PUMP, GBL, 7500, suction, models 245R555 and 25R559	3
10	557128	PLATE, blank, models 24W633 and 24W636	5	▲ Replacement safety labels, tags, and cards are available at no cost			
		PLATE, blank, models 24W634 and 24W635	7	◆ See pump instruction manual 3A2257			

Accessories

Pumps*

Part No.	Description
24J391	3/16 in. Suction Fed Pump
24J392	1/4 in. Suction Fed Pump
24J393	3/8 in. Suction Fed Pump
24J394	3/16 in. Gravity Fed Pump
24J395	1/4 in. Gravity Fed Pump
24J396	3/8 in. Gravity Fed Pump
24J397	3/16 in. Pressure Fed Pump
24J398	1/4 in. Pressure Fed Pump
24J399	3/8 in. Pressure Fed Pump
24K466	Alarm Pump

*See pump instruction manual 3A2257

Adding accessories that alter the original assembly configuration voids the box lubricator's ATEX rating.

Other Accessories*

Part No.	Description	Special Features/Notes
559037	Gravity Supply	Mounted in the last pump station.
		Exception is when an Alarm Pump is used, then this option is mounted in the second to the last pump station.
563013	Low Level Switch	Single-pole, double-throw.
		Meets Explosion Proof Class 1 Group C and D requirements.
		Meets Explosion Proof Class 2 Group E, F, and G requirements.
		Mounted in the last pump station.
		Exception is when an Alarm Pump is used, then this option is mounted in the second to the last pump station.
564015	Low Level Switch	Single-pole, double-throw.
		N.C. Electric Rating is 10 watts @ 10 VAC (minimum)
		Mounted in the last pump station.
		Exception is when an Alarm Pump is used, then this option is mounted in the second to the last pump station.

*Adding accessories that alter the original assembly configuration voids the box lubricator's ATEX rating.

Technical Specifications

Box Lubricator	US	Metric
Pump Size	Maximum Outlet Pressure	Maximum Outlet Pressure
1/4 in.	6000 psi	41.4 MPa, 414 bar
3/8 in.	3500 psi	24.1 MPa, 241 bar
Reservoir Capacity		
Models 24W633, 24W636, 25R513, 25R555, 25R557, 25R559	4 Pints	
Models 24W634, 24W635, 25R514, 25R554, 25R556, 25R558	6 Pints	
Temperature		
Operating Temperature Range, Non-ATEX	-20°F to 140°F	-29°C to 60°C
Operating Temperature Range, ATEX	-4°F to 104°F	-20°C to 40°C
Fluid Viscosity		
Dispensing Fluid Viscosity	80 to 5000 SUS	
Materials of Construction		
Wetted Materials	carbon steel, nylon, fluoroelastomer, cork, brass, aluminum	
Drive		
Drive Speed	1800 rpm max	
Drive Ratio	118:1	

Reservoir and Mounting Dimensions

Dimensions are shown in inches (mm) - See **Dimensions Table**, page 16

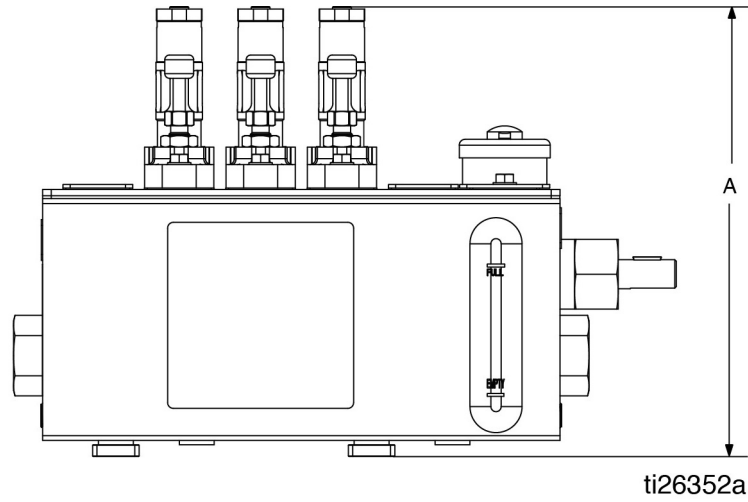

Reservoir and Mounting Dimensions

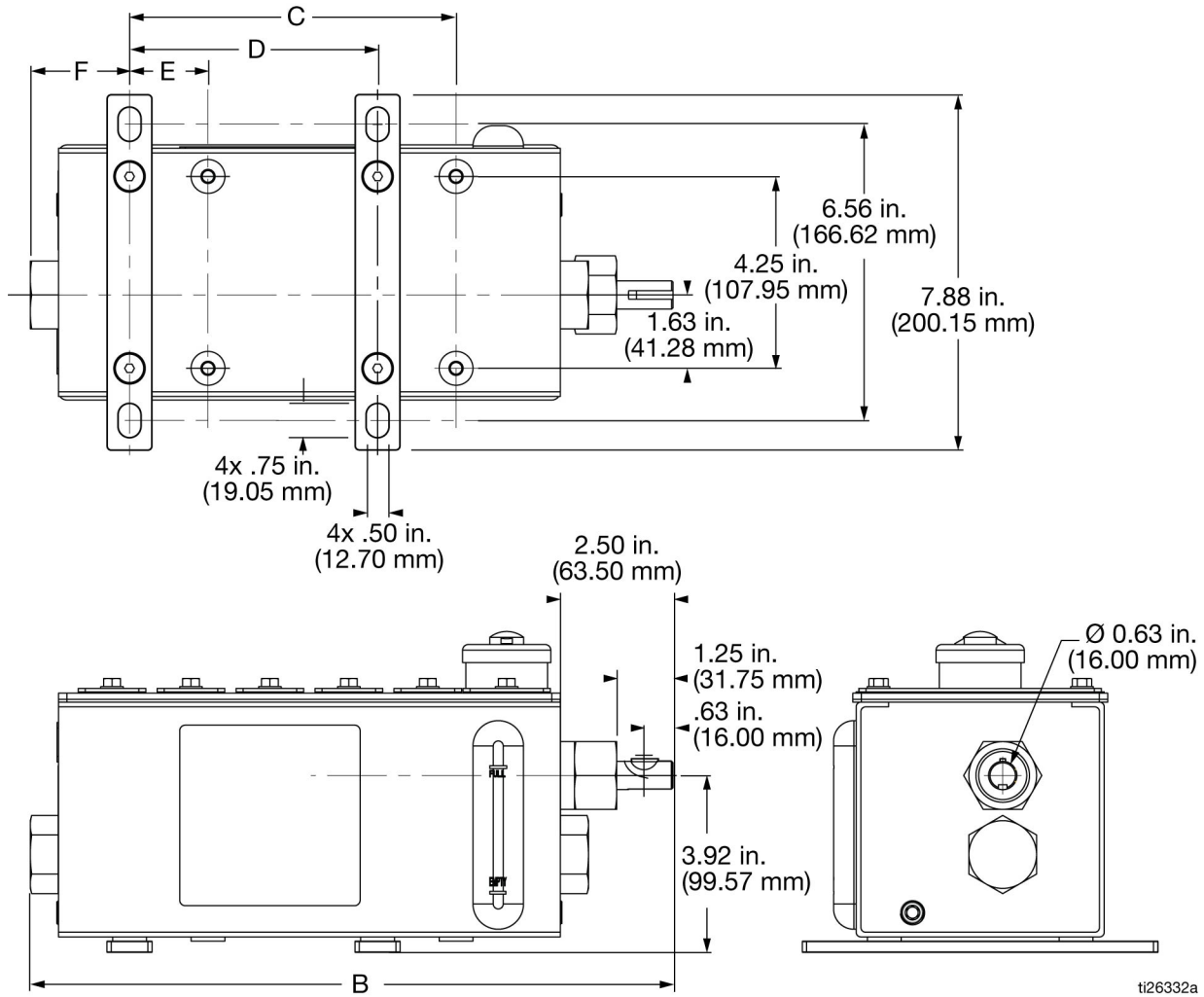

Dimensions Table

Part No.	Description	A		B		C		D		E		F	
		inch	mm	inch	mm	inch	mm	inch	mm	inch	mm	inch	mm
24W633 25R513	Lubricator Reservoir 4 Pint	NA	NA	14.25	361.95	7.24	183.90	5.5	139.7	1.74	44.20	2.20	55.88
24W636 25R555 25R557 25R559	Box Lubricator 4 Pint	9.67	245.62										
24W634 25R514	Lubricator Reservoir 6 Pint	NA	NA	15.88	403.35	8.75	222.25	NA	NA	NA	NA	2.33	59.18
24W635 25R554 25R556 25R558	Box Lubricator 6 Pint	9.67	245.62										

California Proposition 65

CALIFORNIA RESIDENTS

 **WARNING:** Cancer and reproductive harm – www.P65warnings.ca.gov.

Graco Standard Warranty

Graco warrants all equipment referenced in this document which is manufactured by Graco and bearing its name to be free from defects in material and workmanship on the date of sale to the original purchaser for use. With the exception of any special, extended, or limited warranty published by Graco, Graco will, for a period of twelve months from the date of sale, repair or replace any part of the equipment determined by Graco to be defective. This warranty applies only when the equipment is installed, operated and maintained in accordance with Graco's written recommendations.

This warranty does not cover, and Graco shall not be liable for general wear and tear, or any malfunction, damage or wear caused by faulty installation, misapplication, abrasion, corrosion, inadequate or improper maintenance, negligence, accident, tampering, or substitution of non-Graco component parts. Nor shall Graco be liable for malfunction, damage or wear caused by the incompatibility of Graco equipment with structures, accessories, equipment or materials not supplied by Graco, or the improper design, manufacture, installation, operation or maintenance of structures, accessories, equipment or materials not supplied by Graco.

This warranty is conditioned upon the prepaid return of the equipment claimed to be defective to an authorized Graco distributor for verification of the claimed defect. If the claimed defect is verified, Graco will repair or replace free of charge any defective parts. The equipment will be returned to the original purchaser transportation prepaid. If inspection of the equipment does not disclose any defect in material or workmanship, repairs will be made at a reasonable charge, which charges may include the costs of parts, labor, and transportation.

THIS WARRANTY IS EXCLUSIVE, AND IS IN LIEU OF ANY OTHER WARRANTIES, EXPRESS OR IMPLIED, INCLUDING BUT NOT LIMITED TO WARRANTY OF MERCHANTABILITY OR WARRANTY OF FITNESS FOR A PARTICULAR PURPOSE.

Graco's sole obligation and buyer's sole remedy for any breach of warranty shall be as set forth above. The buyer agrees that no other remedy (including, but not limited to, incidental or consequential damages for lost profits, lost sales, injury to person or property, or any other incidental or consequential loss) shall be available. Any action for breach of warranty must be brought within two (2) years of the date of sale.

GRACO MAKES NO WARRANTY, AND DISCLAIMS ALL IMPLIED WARRANTIES OF MERCHANTABILITY AND FITNESS FOR A PARTICULAR PURPOSE, IN CONNECTION WITH ACCESSORIES, EQUIPMENT, MATERIALS OR COMPONENTS SOLD BUT NOT MANUFACTURED BY GRACO. These items sold, but not manufactured by Graco (such as electric motors, switches, hose, etc.), are subject to the warranty, if any, of their manufacturer. Graco will provide purchaser with reasonable assistance in making any claim for breach of these warranties.

In no event will Graco be liable for indirect, incidental, special or consequential damages resulting from Graco supplying equipment hereunder, or the furnishing, performance, or use of any products or other goods sold hereto, whether due to a breach of contract, breach of warranty, the negligence of Graco, or otherwise.

FOR GRACO CANADA CUSTOMERS

The Parties acknowledge that they have required that the present document, as well as all documents, notices and legal proceedings entered into, given or instituted pursuant hereto or relating directly or indirectly hereto, be drawn up in English. Les parties reconnaissent avoir convenu que la rédaction du présente document sera en Anglais, ainsi que tous documents, avis et procédures judiciaires exécutés, donnés ou intentés, à la suite de ou en rapport, directement ou indirectement, avec les procédures concernées.

Graco Information

For the latest information about Graco products, visit www.graco.com.

For patent information, see www.graco.com/patents.

TO PLACE AN ORDER, contact your Graco distributor or call to identify the nearest distributor.

Phone: 612-623-6928 **or Toll Free:** 1-800-533-9655, **Fax:** 612-378-3590

All written and visual data contained in this document reflects the latest product information available at the time of publication. Graco reserves the right to make changes at any time without notice.

Original instructions. This manual contains English. MM 3A3006

Graco Headquarters: Minneapolis

International Offices: Belgium, China, Japan, Korea

GRACO INC. AND SUBSIDIARIES • P.O. BOX 1441 • MINNEAPOLIS MN 55440-1441 • USA
Copyright 2015, Graco Inc. All Graco manufacturing locations are registered to ISO 9001.

www.graco.com
Revision H, March 2024