

Electric Back-Gear Drum Agitators

3A4548H
EN

Heavy duty, back-gearred agitator for mixing and maintaining suspension of industrial coatings stored in 55 gallon drums. For professional use only.



Important Safety Instructions

Before using this equipment, read all warnings and instructions in this manual and associated component manuals. **Save all instructions and keep them in the workplace.**

See page 3 for a complete list of model descriptions and part numbers.

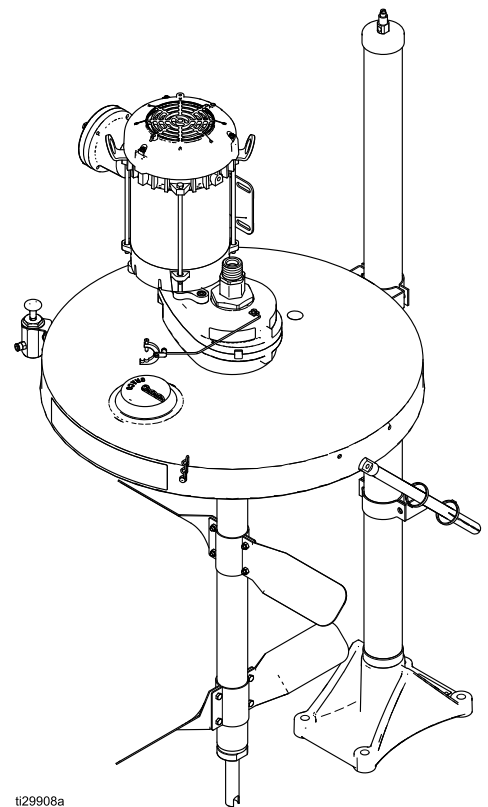

Contents

Related Manuals	2	Cleaning the Agitator Shaft — Models with Siphon Kit	13
Models	3	Servicing the Gear Reducer	13
Warnings	5	Additional Agitator Service	14
Installation	7	Parts	15
Back-Gear Mounting Hole Dimensions	7	Models 25C483 and 25C484	15
Assembling and Positioning the Agitator	7	Models 25C485, 25C486, 25C487, 25C488	17
With or Without an Elevator	8	Models 25C374, 25C451, 25C480, 25C481	19
Installing the Siphon Kit	9	Accessories	20
VFD	9	Dimensions	21
Connect VFD to Motor	9	Models 25C483 and 25C484	21
Installations with Elevators	10	Models 25C485, 25C486, 25C487, 25C488	22
Grounding the Agitator	10	Models 25C374, 25C451, 25C480, 25C481	24
Operation	11	Power Usage Charts	26
Pre-Start Checklist	11	Technical Specifications	27
General Operation	11	California Proposition 65	27
Installations with Elevators	11		
Finding the Proper Agitator Speed	12		
Service	13		
Cleaning the Agitator Shaft and Seal	13		

Related Manuals

Manual Number	Title
3A4793	VFD (Variable Frequency Drive)
306287	Elevators and Pump Supports
308466	Drum Covers, Stainless Steel, Passivated
Card P/N 4054	Leeson® Electric Corporation, General Installation and Operating Instructions (for UL Listed motors)
Número: UM-3.1	cemp Flameproof Electric Motors, ATEX safety instructions

Models

The Electric Back-Gear Agitator requires power from a variable frequency drive (VFD) to control speed and is not to be used without one. See the VFD manual 3A4793 for a listing of part numbers for related VFD motor controls, to be ordered separately. See [Technical Specifications, page 27](#) for motor ratings.

Table 1 Base Models Explosion Proof Inverter Duty Motor





PN	Desc	Motor	Motor Hazardous Location Approvals
25C483	Back-Gear, Drive Only, with Ground Wire Kit	UL Listed	 
PN		Motor	Agitator Approval
25C484		ATEX Listed	   <p>II 1/2 G Ex h IIB T4 Ga/Gb IECEX ETL 17.0019 ITS17ATEX1001809 ITS21UKEX0387 0°C ≤ Tamb ≤ 40°C</p>

Table 2 Models with UL Listed Explosion Proof Inverter Duty Motor (with 25C483)









PN	Desc	Shaft and Blades	Siphon	Drum Cover	Elevator and Cover Support	Elevator Air Control	Motor Hazardous Location Approvals
25C485	Agitator	◆					 
25C486	Agitator with Siphon	◆	◆				
25C374	Agitator with Drum Cover and Elevator	◆		◆	◆	◆	
25C451	Agitator with Drum Cover, Elevator, and Siphon	◆	◆	◆	◆	◆	





Table 3 Models with ATEX Listed Explosion Proof Inverter Duty Motor (with 25C484)









PN	Desc	Shaft and Blades	Siphon	Drum Cover	Elevator and Cover Support	Elevator Air Control	Approvals
25C487	Agitator	◆					 <p>II 1/2 G Ex h IIB T4 Ga/Gb IECEX ETL 17.0019 ITS17ATEX1001809 ITS21UKEX0387 0°C ≤ Tamb ≤ 40°C</p>
25C488	Agitator with Siphon	◆	◆				
25C481	Agitator with Drum Cover and Elevator	◆		◆	◆	◆	 <p>Includes ATEX and IECEX approvals of agitator 25C487</p>
25C480	Agitator with Drum Cover, Elevator, and Siphon	◆	◆	◆	◆	◆	 <p>Includes ATEX and IECEX approvals of agitator 25C488</p>

Warnings

The following warnings are for the setup, use, grounding, maintenance, and repair of this equipment. The exclamation point symbol alerts you to a general warning and the hazard symbols refer to procedure-specific risks. When these symbols appear in the body of this manual or on warning labels, refer back to these Warnings. Product-specific hazard symbols and warnings not covered in this section may appear throughout the body of this manual where applicable.

 DANGER	
 	<p>HIGH VOLTAGE ELECTRIC SHOCK HAZARD</p> <p>This equipment uses high voltage power. Improper contact with high voltage equipment will cause death or serious injury.</p> <ul style="list-style-type: none"> • Turn off and disconnect power at main switch before disconnecting any cables and before servicing equipment. • This equipment must be grounded. Connect only to grounded power source. • All electrical wiring must be done by a qualified electrician and comply with all local codes and regulations.

 WARNING	
   	<p>FIRE AND EXPLOSION HAZARD</p> <p>Flammable fumes, such as solvent and paint fumes, in work area can ignite or explode. Paint or solvent flowing through the equipment can cause static sparking. To help prevent fire and explosion:</p> <ul style="list-style-type: none"> • Use equipment only in well ventilated area. • Eliminate all ignition sources; such as pilot lights, cigarettes, portable electric lamps, and plastic drop cloths (potential static arc). • Ground all equipment in the work area. See Grounding instructions. • Never spray or flush solvent at high pressure. • Keep work area free of debris, including solvent, rags and gasoline. • Do not plug or unplug power cords, or turn power or light switches on or off when flammable fumes are present. • Use only grounded hoses. • Hold gun firmly to side of grounded pail when triggering into pail. Do not use pail liners unless they are antistatic or conductive. • Stop operation immediately if static sparking occurs or you feel a shock, Do not use equipment until you identify and correct the problem. • Keep a working fire extinguisher in the work area.

 <h1 style="margin: 0;">WARNING</h1>	
 	<p>EQUIPMENT MISUSE HAZARD Misuse can cause death or serious injury.</p> <ul style="list-style-type: none"> • Do not operate the unit when fatigued or under the influence of drugs or alcohol. • Do not exceed the maximum working pressure or temperature rating of the lowest rated system component. See Technical Data in all equipment manuals. • Use fluids and solvents that are compatible with equipment wetted parts. See Technical Data in all equipment manuals. Read fluid and solvent manufacturer's warnings. For complete information about your material, request SDS from distributor or retailer. • Do not leave the work area while equipment is energized or under pressure. • Check equipment daily. Repair or replace worn or damaged parts immediately with genuine manufacturer's replacement parts only. • Do not alter or modify equipment. Alterations or modifications may void agency approvals and create safety hazards. • Make sure all equipment is rated and approved for the environment in which you are using it. • Use equipment only for its intended purpose. Call your distributor for information. • Route hoses and cables away from traffic areas, sharp edges, moving parts, and hot surfaces. • Do not kink or over bend hoses or use hoses to pull equipment. • Keep children and animals away from work area. • Comply with all applicable safety regulations.
 	<p>MOVING PARTS HAZARD Moving parts can pinch, cut or amputate fingers and other body parts.</p> <ul style="list-style-type: none"> • Keep clear of moving parts. • Do not operate equipment with protective guards or covers removed. • Before checking, moving, or servicing equipment, disconnect all power sources.
 	<p>TOXIC FLUID OR FUMES Toxic fluids or fumes can cause serious injury or death if splashed in the eyes or on skin, inhaled, or swallowed.</p> <ul style="list-style-type: none"> • Read Safety Data Sheet (SDS) to know the specific hazards of the fluids you are using. • Store hazardous fluid in approved containers, and dispose of it according to applicable guidelines.
	<p>BURN HAZARD Equipment surfaces and fluid that is heated can become very hot during operation. To avoid severe burns:</p> <ul style="list-style-type: none"> • Do not touch hot fluid or equipment.
	<p>PERSONAL PROTECTIVE EQUIPMENT Wear appropriate protective equipment when in the work area to help prevent serious injury, including eye injury, hearing loss, inhalation of toxic fumes, and burns. Protective equipment includes but is not limited to:</p> <ul style="list-style-type: none"> • Protective eyewear and hearing protection. • Respirators, protective clothing, and gloves as recommended by the fluid and solvent manufacturer.

Installation

Back-Gear Mounting Hole Dimensions

If using a new drum cover without holes, see below for hole spacing dimensions.

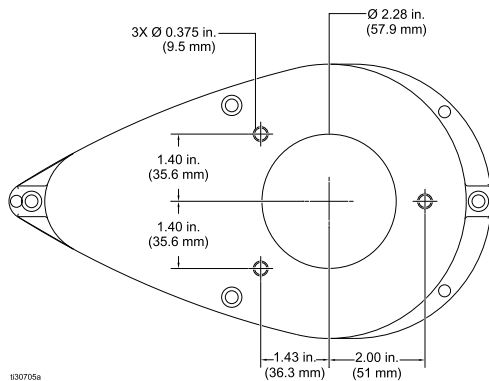

Assembling and Positioning the Agitator

<p>All electrical wiring must be done by a qualified electrician and comply with all local codes and regulations. Only trained and qualified personnel who have read and who understand the information in this manual should install this equipment.</p> <p>Always maintain a minimum of 1 in. (25.4 mm) clearance between rotating agitator parts and container to prevent sparks from contact.</p> <p>Personal injury or equipment damage may result from lifting/falling heavy equipment. To avoid personal injury or equipment damage:</p> <ul style="list-style-type: none"> • Do not lift the drum cover and agitator without proper assistance • Do not walk or stand beneath a raised elevator. 				

With an Elevator

Mount the drum cover as described in manual 306287, *Elevators and Pump Supports*.

The elevator must be in the down position when working on the elevator, agitator, or drum cover assembly (for elevator operating instructions, see manual 306287, *Elevators and Pump Supports*). Proceed to step 1 in [With or Without an Elevator, page 8](#).

Without an Elevator

If your system does not have an elevator, install the Handles Kit to facilitate handling the drum cover and agitator. *To order the Handles Kit, order Part No. 237524.*

Place two standard 55 U.S. gallon (45 Imperial gallon) barrels 14 in. (approximately 36 cm) apart, and center the drum cover on the barrels with the Graco logo centered and facing you, as shown in Fig. 1. Proceed to step 1 in [With or Without an Elevator, page 8](#).

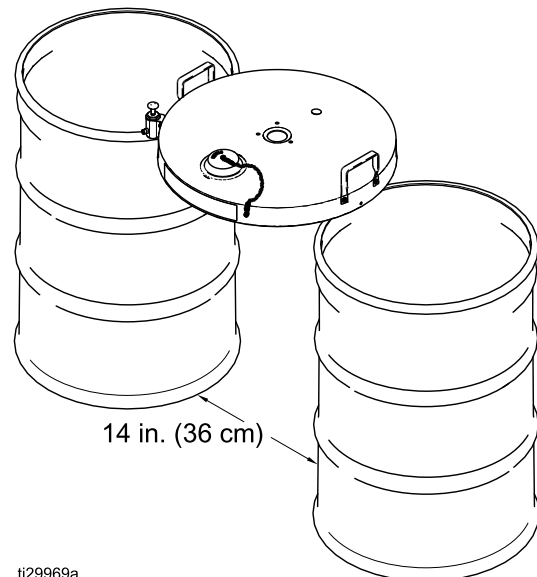

Figure 1 Drum Cover on Barrels

With or Without an Elevator

1. Install the agitator shaft (33) by threading it into the stub (6) on the bottom of the back-gear housing (1). See Figure 2.
2. Slide the agitator shaft through the large hole in the center of the drum cover (not shown).
3. Rotate and align the three tapped holes in the bottom of the back-gear housing with the three through holes in the drum cover.
4. Thread three hex head screws (45 not shown) with thread sealant (not provided) up through the drum cover and into the bottom of the housing. Torque them to 75 in-lb (8.4 N-m).
5. Assemble one pair of agitator blades (34) so that the four holes in the blade halves are lined up.
6. Push four cap screws (35) through the four holes in the blades, and start the four lock nuts (36) onto the cap screws.
7. Slide the loose blade assembly up the shaft, and position it approximately 13 in. (33 cm) from the bottom of the shaft.
8. Tighten the lock nuts evenly to draw the blades together until they are tight on the shaft. Torque the locknuts to 50 to 55 in-lb (5.6 to 6.2 N-m). A gap will remain between the blade halves.
9. Repeat steps 5 and 6 with the second pair of agitator blades.
10. Position the second blade assembly near the bottom end of the shaft, but not on the bottom plug (40).
11. Rotate the lower blade assembly so that it is oriented 90 degrees relative to the upper blade assembly, and torque the lock nuts to 50 to 55 in-lb (5.6 to 6.2 Nm). A gap will remain between the blade halves.

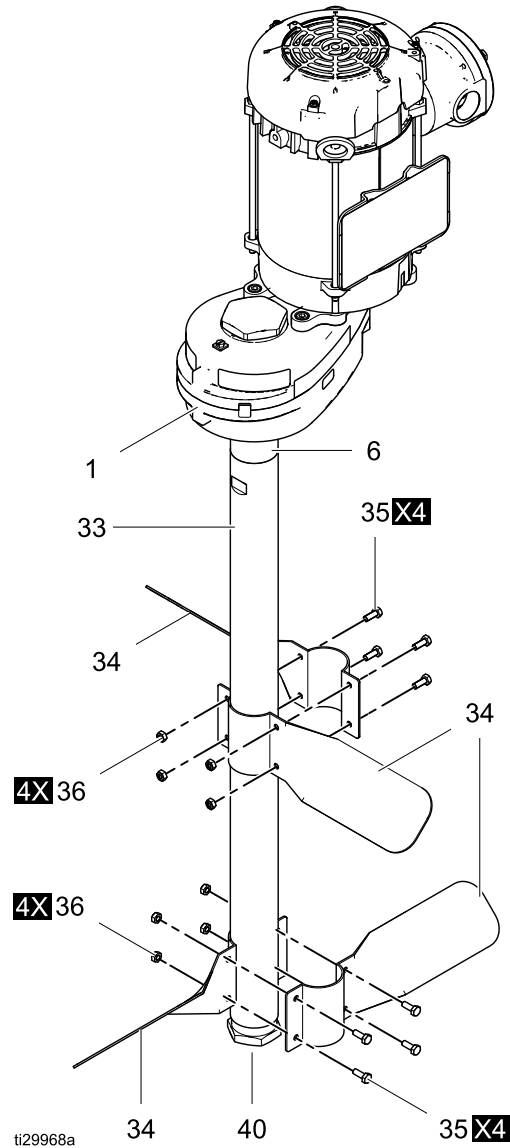

Figure 2 Agitator Shaft and Blades

Installing the Siphon Kit

1. Replace the bottom plug (40) with the plain bearing (37d), and tighten the bearing with a wrench. See Figure 3.
2. Work the o-ring (37e) onto the siphon tube retainer (37b), and press it into the o-ring groove.
3. Replace the top plug (26) with the siphon tube retainer/o-ring just assembled. Leave the retaining nut (37c) on the siphon tube retainer, but make sure it is not tightened. Tighten the siphon tube retainer/o-ring into the top of the agitator housing with a wrench.
4. Slide the siphon tube (37a) down through the retaining nut, siphon tube retainer, and agitator shaft until the siphon tube touches the bottom of the drum. Raise the siphon tube approximately 1/4 in. (approximately 6 mm) so that it does not touch the bottom of the drum. Hold the siphon tube at this height with one hand, and tighten the retaining nut with the other hand (hand-tight is enough to hold the siphon tube in place).

NOTICE

Barrel Heights Vary.

Loosen the retaining nut on the siphon tube retainer before you raise the drum cover. If you do not loosen the retaining nut, the siphon tube may make contact with the bottom of the barrel when you lower the drum cover onto a new barrel, which could damage the siphon tube or the barrel.

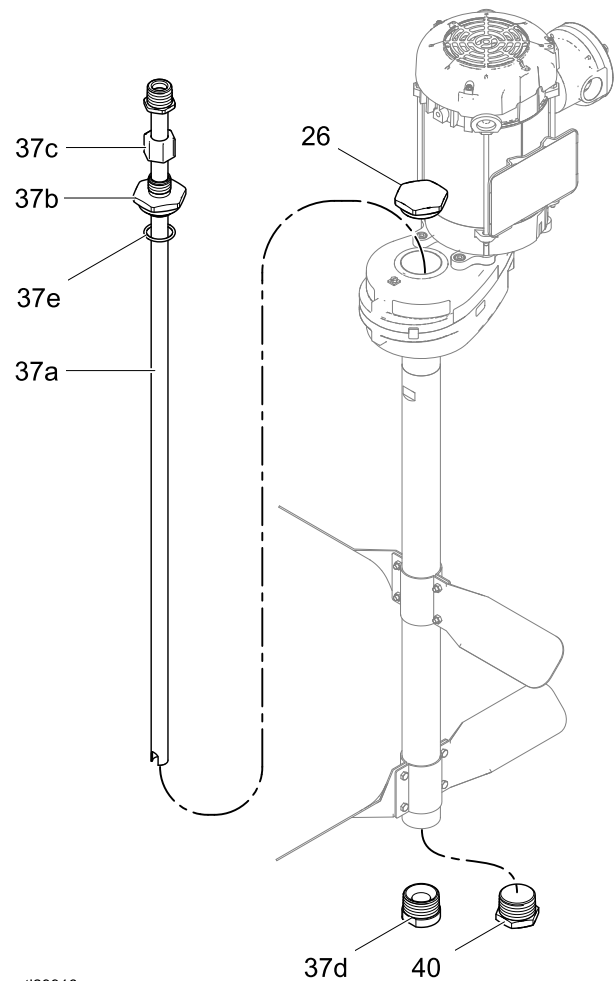

ti29916a

Figure 3 Siphon Tube

VFD

See the VFD manufacturer's manual for information on installation and operation of the VFD.

For a Graco supplied VFD, see manual 3A4793 for information on VFD installation and operation.

Connect VFD to Motor

NOTICE

To avoid equipment damage, do not plug the motor directly into a wall socket. The motor must be wired to a VFD.

Follow the instructions in the motor manufacturer's manual provided with this agitator to connect the VFD to the motor. Wire size, fuse size, and other electrical devices must comply with all local codes and regulations.

Installation

Motors are equipped with an automatic thermal protective device. Review the warning label on the motor stating the requirement for connecting to the control circuit terminals of the VFD. UL and NEC require connection of motor thermostat leads P1 and P2 into the control portion of a manual reset start circuit.

For Graco supplied VFDs, motor thermostat leads P1 and P2 connect to terminals 4 and 13B on the VFD, as shown below.

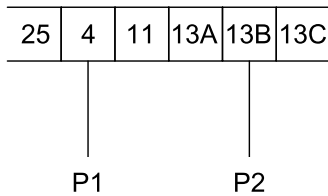

MOTOR THERMOSTAT LEADS

For ATEX motors, follow the thermal protection wiring requirements described in the ATEX motor manual. The ATEX motor manual is included with the agitator.

For Non-Graco supplied VFD — see the motor Installation manual for instructions to connect to the VFD.

Installations with Elevators

<p>To reduce the risk of serious injury, including cuts, amputation of fingers by the agitator blades, and splashing in the eyes or on the skin, always power off the VFD before raising, checking, or repairing the agitator.</p> <p>Equipment surfaces and fluid that is heated can become very hot during operation, resulting in severe burns. To avoid severe burns do not touch hot fluid or equipment.</p>				

Hazardous locations: Install a hazardous location approved electrical disconnect switch near the agitator. This switch enables the operator to stop the agitator before lifting the elevator and drum lid.

Grounding the Agitator

<p>The equipment must be grounded to reduce the risk of static sparking and electric shock. Electric or static sparking can cause fumes to ignite or explode. Improper grounding can cause electric shock. Grounding provides an escape wire for the electric current.</p>				

The drum cover and all electrically conductive objects or devices in the dispensing area must be properly grounded. Check your local electrical code for detailed grounding instructions for your area and type of equipment.

To ground the agitator, connect one end of the ground wire (A) to the ground connector (B) on the agitator. Connect the other end of the ground wire to a true earth ground.

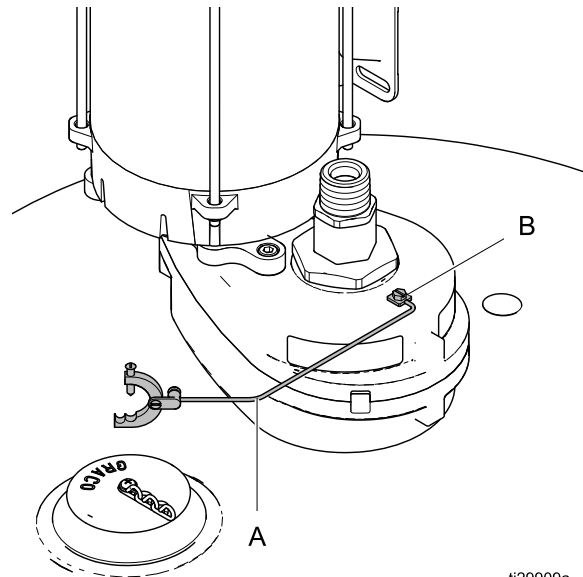







Figure 4 Agitator Ground

ti29909a

Operation

				
<p>To reduce the risk of serious injury, including cuts, amputation of fingers by the agitator blades, and splashing in the eyes or on the skin, always power off and disconnect power to the VFD before raising, checking, or repairing the agitator.</p> <p>Equipment surfaces and fluid that is heated can become very hot during operation, resulting in severe burns. To avoid severe burns do not touch hot fluid or equipment.</p>				

Pre-Start Checklist

Verify each of the following items before starting the pump.

- **DEBRIS:** Ensure that the drum is free of any contaminants or debris that will block blade movement.
- **HOSE MATERIAL:** Check that the hose material is compatible with the fluid being pumped. Consult your Graco distributor for available hose materials.
- **FASTENERS:** Check that all fasteners are properly tightened.
- **LEAKS:** Check the suction line connection to verify there are no leaks and that all fittings are tight.

NOTICE

To avoid equipment damage, be sure the motor rotation is set in a clockwise rotation — when looking down on the motor fan blade and agitator blade. Counterclockwise rotation will potentially damage the gear box and loosen the agitator shaft. See the VFD manufacturer's manual for information on setting rotation direction, or for a Graco supplied VFD, see manual 3A4793.

General Operation

Use the VFD to start, stop, and adjust the agitator speed. See the VFD manufacturer's manual for operating information. For a Graco supplied VFD, see manual 3A4793 for operating information.

Agitators are used to maintain solids in suspension. If solids have settled in the container, use a shaker or some other device to bring product back in suspension before installing and operating the agitator.

Installations with Elevators

Before raising the elevator and drum lid, make sure to shut off power to the electrical motor on the agitator. Shut off power at the disconnect switch installed near the agitator.

Finding the Proper Agitator Speed

NOTE: Always maintain moderate agitator speed, which is approximately 20 to 40 rpm of the agitator shaft. Excessive agitator speed may cause vibration, foaming of fluid, and increased wear on parts. Always agitate fluid thoroughly before supplying it to the dispensing equipment. Continue agitating fluid while the dispensing equipment is being supplied.



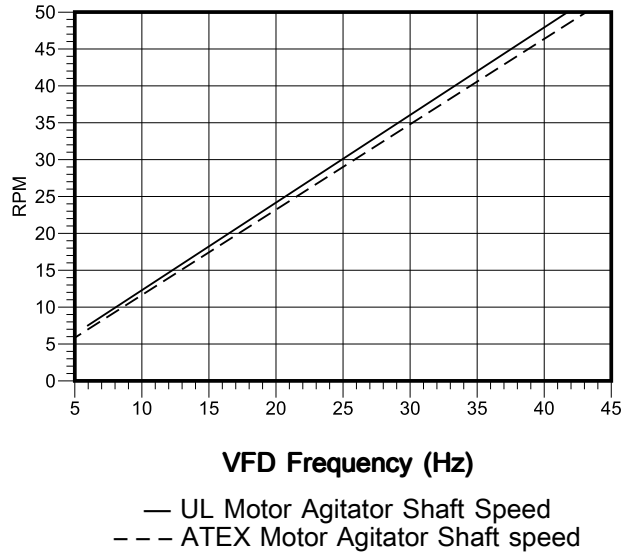

The agitator shaft speed can be calculated by using the formula below or determined by the graph below using the VFD frequency.

Example 1: $(A \div B) \times C = D \div E = F$			
Example 2: $(40 \text{ hz} \div 60 \text{ hz}) \times 1725 \text{ rpm} = 1150 \text{ rpm (motor)} \div 24 \text{ (gear reduction)} = 48 \text{ rpm (agitator shaft)}$			
A	VFD Frequency	D	Motor RPM
B	Motor Frequency	E	Gear Reduction
C	Motor Speed	F	Agitator RPM

Agitator Shaft Speed



Service

				
<ul style="list-style-type: none"> • Moving parts, such as an impeller blade, can pinch or amputate fingers. To reduce risk of injury, always disconnect power from the agitator before performing maintenance or service. • Improper handling of hazardous fluids or inhaling toxic fumes can cause serious injury due to splashing in the eyes, ingestion, or bodily contamination. 				

Cleaning the Agitator Shaft and Seal

NOTICE

Keep the agitator upright. Do not lay it on its side or upside down or liquid may flow down the shaft and into the gear reducer area, which will damage the equipment.

If any material is on the shaft stub (6) within 1/2 in. (13 mm) of the housing (1), it must be removed to prevent damage to the bearing seal (13). See [Parts, page 15](#). If the flexible lips on the bearing seal are torn or worn such that they do not make contact all the way around the shaft, the seal must be replaced. A worn seal may allow foreign material into the bearing and cause premature failure. See [Servicing the Gear Reducer, page 13](#) for instructions on getting access to the seal and for the Bearing Replacement Kit Part No.

Cleaning the Agitator Shaft — Models with Siphon Kit

Follow the procedure below to flush and clean the siphon tube and agitator shaft. See [Models 25C485, 25C486, 25C487, 25C488, page 17](#) for part reference identification.



1. Disconnect the VFD power supply.
2. Raise the agitator out of the drum.
3. Remove the plain bearing (37d) from the agitator shaft and clean it.
4. Detach any siphon tube attachments and flush the siphon tube (37a).
5. Loosen the retaining nut (37c) on the siphon tube and slowly lift the siphon tube out of the agitator.

6. Clean the inside and outside of the siphon tube, flush the inside of the agitator shaft (33), and clean the agitator blades (34) and the outside of the shaft.
7. Reassemble the siphon tube by doing the reverse of steps 2 through 4.

Servicing the Gear Reducer

The Bearing Replacement Kit should be on hand before beginning this procedure. *To order a Bearing Replacement Kit, order Part Number 238251.*

Disassembling

				
<p>Personal injury or equipment damage may result from lifting/falling heavy equipment. To avoid personal injury or equipment damage, do not lift the drum cover and agitator without proper assistance</p>				

Motor and mounting plate assembly weigh approximately 45 lbs (20 kg). Verify that adequate personnel are available or a secure lifting device is available for use in positioning and installing.

The following procedure does not require agitator removal from the drum. See [Parts, page 15](#) for part reference identification.

1. Disconnect the VFD power supply.
2. Remove the two set screws (17) and the two motor mounting plate screws (32). Remove the motor assembly from the back-gear housing
3. If your agitator has a siphon kit, do steps 2 through 4 in [Cleaning the Agitator Shaft — Models with Siphon Kit, page 13](#) and then continue with step 3 below. If your agitator does not have a siphon kit, proceed to step 3 below.
4. Raise and support the drum cover above the drum high enough to reach the underside.
5. Remove the three hex head screws holding the agitator to the drum cover.
6. Raise the agitator housing 4 to 6 in. (100 to 150 mm) above the drum cover, and support it at that height with blocks.
7. Tightly grip the agitator shaft (6) with a clamp to prevent the shaft from falling into the drum.
8. Remove the two short bolts (11) and the two long bolts (19) that hold the upper housing (2) and the lower housing (1) together. Carefully lift the upper housing straight up off of the lower housing.

NOTE: Before doing the following step, be sure the agitator shaft is well secured. See step 6.

Service

- Turn the large gear (9) counter-clockwise to remove it from the agitator shaft, and lift the pinion/gear assembly (10, 15) out of the lower housing. Do not lose the two small thrust balls (4). One in the upper housing, and one in the lower housing.
- Turn the 50 mm nut (18) counter-clockwise to remove it from the agitator shaft.
- Carefully lift the lower housing off of the agitator shaft.

Cleaning and Servicing

- Clean any foreign material from the outside of the upper and lower housings (1 and 2). See [Parts, page 15](#).
- Inspect the parts for any wear. If any of the parts are worn or damaged, replace them. The Bearing Replacement Kit contains replacement bearings, seals, and balls.

Reassembling

- Reposition the lower housing (1) on the agitator shaft stub (6). See [Parts, page 15](#).

NOTICE

To prevent damage to the bearings and seals, avoid scraping them against the threaded agitator shaft while lowering the lower housing in place.

- Thread the 50-mm nut (18) onto the agitator shaft by turning it clockwise, and tighten it hand tight.

- Reposition the pinion/gear assembly (10, 15) in the lower housing, thread the large gear (9) onto the agitator shaft, and tighten the large gear hand tight.
- Make sure the small thrust balls (4) are in place.
- Carefully lowering it straight down, reposition the upper housing (2) on the lower housing (1).
- Replace the two short bolts (11) and the two long bolts (19) that hold the upper housing and the lower housing together, and torque the bolts to 75 in-lb (8.5 N-m).
- Remove the blocks supporting the agitator housing, and reposition the agitator on the drum cover.
- Thread the three hex head screws up through the drum cover and into the agitator, and torque them to 75 in-lb (8.4 N-m).
- If your agitator has a siphon kit, re-install it by doing the reverse of steps 2 through 4 in [Cleaning the Agitator Shaft — Models with Siphon Kit, page 13](#).

Additional Agitator Service

If the unit requires more than installation of a bearing replacement kit or gear replacement, it is advisable to send the unit to a Graco distributor for repair or replacement.

Parts

Models 25C483 and 25C484

Back-Gear Drive

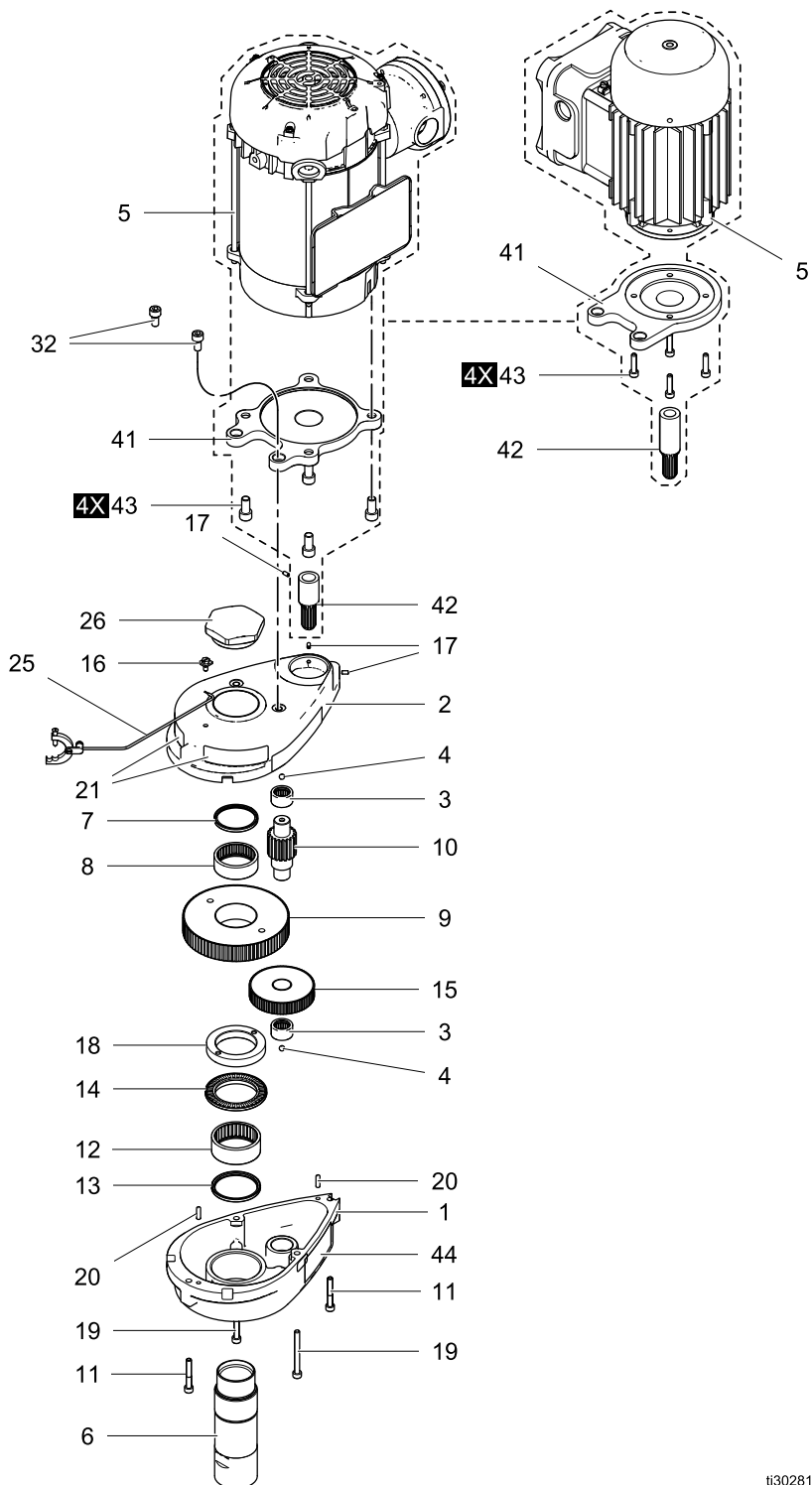

ti30281a

Parts

Ref No.	Part No.	TEST	Qty
1	194390	HOUSING, BOTTOM	1
2	194389	HOUSING, TOP	1
3	191004	BEARING, NEEDLE	2
4	100069	BALL	2
5	25C967	MOTOR, UL LISTED; 3/4 hp, 230/460, TEFC, XP, 60 HZ (model 25C483)	1
	25C968	MOTOR, ATEX; 0.37 kW, 230/400 V, TEFC, XP 50 HZ (model 25C484)	1
6	16A519	STUB, SHAFT, AGITATOR	1
7	113363	SEAL, BEARING	1
8	190980	BEARING, NEEDLE	1
9	190989	GEAR	1
10	190988	GEAR, PINION	1
11	113357	SCREW, CAP, SOCKET HEAD; M6 x 1 x 40 MM	2
12	190978	BEARING, NEEDLE	1
13	113359	SEAL, BEARING	1
14	190979	BEARING, NEEDLE, THRUST	1
15	190987	GEAR	1
16	116343	SCREW, GROUND, WASHER HEAD; M5 x 0.45 x 8 mm	1
17	108161	SCREW, SET, SOCKET HEAD CAP; M4 x 0.7 x 8 mm	3
18	190976	NUT, 50 MM	1

Ref No.	Part No.	TEST	Qty
19	113356	SCREW, CAP, SOCKET HEAD; M6 x 1 x 60 mm	2
20	105489	PIN, DOWEL	2
21	17N919	LABEL, ARROW, ROTATION	2
25	237569	WIRE, ASSEMBLY, 25 FT	1
26	191003	PLUG, TOP	1
32	117536	SCREW, CAP, SOCKET HEAD; M8 x 1.25 x 25 mm	2
41	17N540	PLATE, ADAPTER (model 25C483)	1
	17P439	PLATE, ADAPTER (model 25C484)	1
42	17N541	GEAR, PINION; 0.625 ID (model 25C483)	1
	17N809	GEAR, PINION; 14 mm ID, (model 25C484)	1
43	100659	SCREW, CAP, SOCKET HEAD; 3/8-16 (model 25C483)	4
	107530	SCREW, CAP, SOCKET HEAD; M6 x 12 mm, (model 25C484)	4
44▲	17R088	LABEL, WARNING	1
45	113358	SCREW, CAP, HEX HEAD; Stainless Steel, M8 x 1.25 x 20 mm (not shown)	3
▲ Replacement, Danger, and Warning labels, signs, tags, and cards are available at no cost.			

Models 25C485, 25C486, 25C487, 25C488

Agitator with or without Siphon

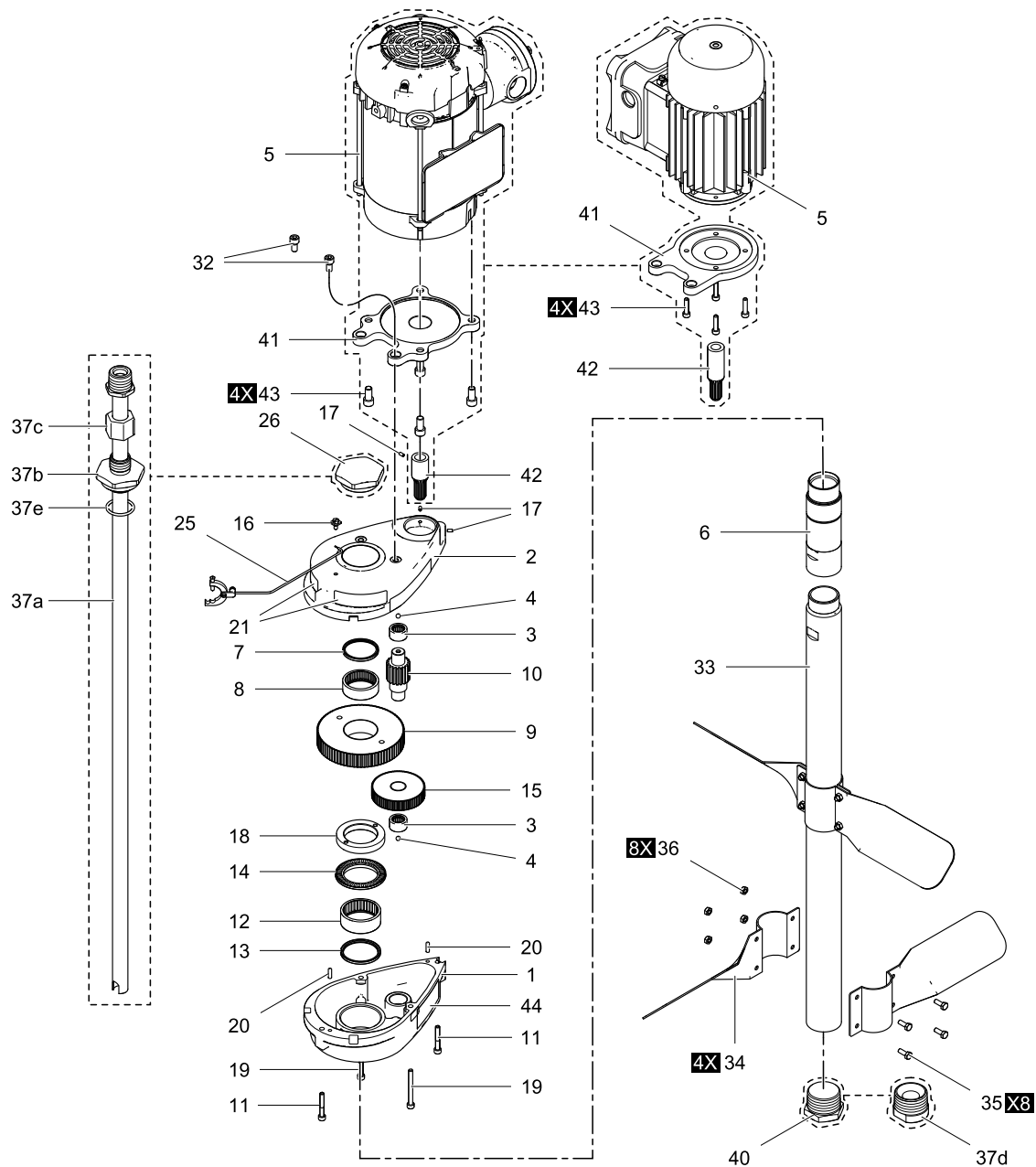

i129917a

Parts

Ref No.	Part No.	Description	Qty
1	194390	HOUSING, BOTTOM	1
2	194389	HOUSING, TOP	1
3	191004	BEARING, NEEDLE	2
4	100069	BALL	2
5	25C967	MOTOR, UL Listed; 3/4 hp, 230/460, TEFC, XP, 60 HZ (model 25C485, 25C486)	1
	25C968	MOTOR, ATEX; 0.37 kW, 230/400 V, TEFC, XP 50 HZ (model 25C487, 25C488)	1
6+	16A519	STUB, SHAFT, AGITATOR	1
7	113363	SEAL, BEARING	1
8	190980	BEARING, NEEDLE	1
9	190989	GEAR	1
10	190988	GEAR, PINION	1
11	113357	SCREW, CAP, SOCKET HEAD; M6 x 1 x 40 mm	2
12	190978	BEARING, NEEDLE	1
13	113359	SEAL, BEARING	1
14	190979	BEARING, NEEDLE, THRUST	1
15	190987	GEAR	1
16	116343	SCREW, GROUND, WASHER HEAD; M5 x 8 mm	1
17	108161	SCREW, SET, SOCKET HEAD CAP; M4 x 0.7 x 8 mm	3
18	190976	NUT, 50 MM	1
19	113356	SCREW, CAP, SOCKET HEAD; M6 x 1 x 60 mm	2
20	105489	PIN, DOWEL	2
21	17N919	LABEL, ARROW, ROTATION	2
25	237569	WIRE, ASSY, 25 FT	1
26	191003	PLUG, TOP (Units without Siphon)	1

Ref No.	Part No.	Description	Qty
32	117536	SCREW, CAP, SOCKET HEAD; M8 x 1.25 x 25 mm	2
33+	24D311	KIT, SHAFT, AGITATOR (includes Ref. No. 6)	1
34	190985	BLADE, AGITATOR, 55 GALLON, 20 inch (50.8 cm) diameter (assembled) (standard)	4
35	113413	SCREW, CAP, HEX HEAD; M6 x 1 x 16 mm	8
36	113414	NUT, LOCK	8
37*	238250	KIT, SIPHON (For units with siphon)	1
40	191002	PLUG, PIPE (For units without siphon)	1
41	17N540	PLATE, ADAPTER (models 25C485, 25C486)	1
	17P439	PLATE, ADAPTER (models 25C487, 25C488)	1
42	17N541	GEAR, PINION; 0.625 ID (models 25C485, 25C486)	1
	17N809	GEAR, PINION; 14 mm ID, (models 25C487, 25C488)	1
43	100659	SCREW, CAP, SOCKET HEAD; 3/8-16 (models 25C485, 25C486)	4
	107530	SCREW, CAP, SOCKET HEAD; M6 x 12 mm (models 25C487, 25C488)	4
44▲	17R088	LABEL, WARNING	1
45	113358	SCREW, CAP, HEX HEAD; Stainless Steel, M8 x 1.25 x 20 mm (not shown)	3
* Included in Siphon Kit 238250.			
+ Included in Agitator Shaft Kit 24D311.			
▲ Replacement, Danger, and Warning labels, signs, tags, and cards are available at no cost.			

Models 25C374, 25C451, 25C480, 25C481

Agitator with Drum Cover and Elevator (elevator maximum working pressure 100 psi, 7 bar)

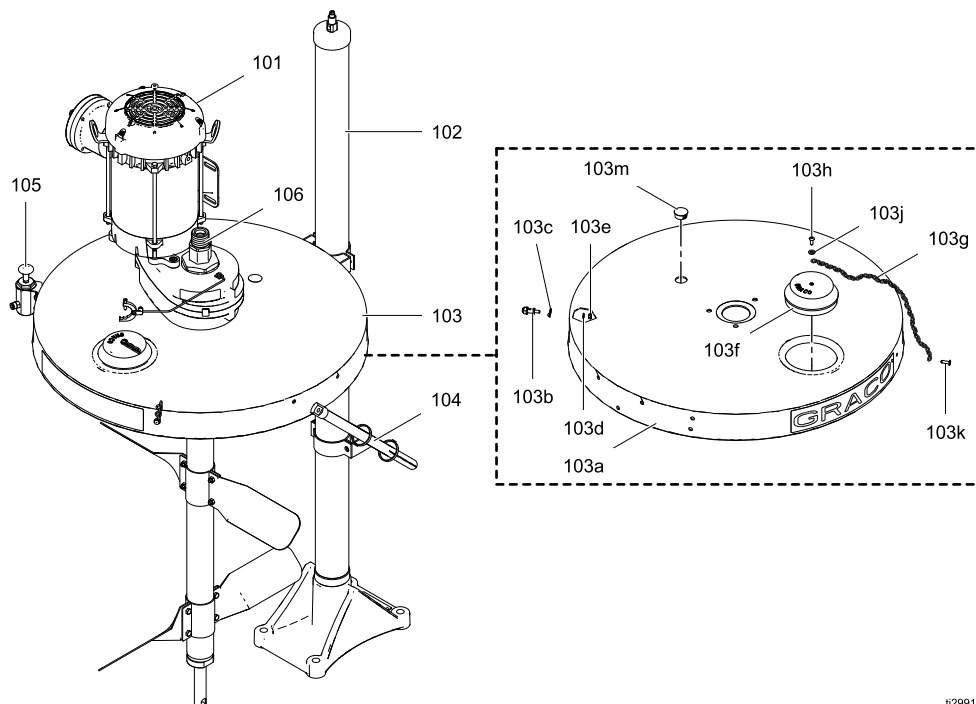

t29918a

Ref No.	Part No.	Description	Qty
101	25C485	AGITATOR, BACK-GEAR (models 25C374, 25C451)	1
	25C487	AGITATOR, BACK-GEAR, ATEX (models 25C480, 25C481)	1
102	204385	ELEVATOR	1
103	238283	COVER, DRUM (models 25C374, 25C451)	1
	See 103a-m	COVER, DRUM (models 25C480, 25C481)	-
103a	190995*	COVER, BARE	1
103b	104029*	STUD, GROUNDING	1
103c	180755*	WASHER, TAB	1
103d	112903*	WASHER, SPRING LOCK; M5, 304 Stainless Steel	1
103e	112899*	NUT, HEX; M5 X 0.8, Stainless Steel	1

Ref No.	Part No.	Description	Qty
103f	237606*	PLUG, POLYETHYLENE	1
103g	068097*	CHAIN, LUG; Stainless Steel	12 inches
103h	112948*	SCREW; 10-32 X 1/2 inch (13 mm); 300 Stainless Steel	1
103j	104116*	WASHER, #10, Stainless Steel	1
103k	113038*	RIVET; Stainless Steel	1
103m	113712*	PLUG, BUTTON	1
104	237578	SUPPORT, COVER ASSEMBLY	1
105	237579	KIT, ACCESSORY, AIR CONTROL	1
106	238250	KIT, SIPHON (used with models 25C451, 25C480)	1

* For use with models 25C480 and 25C481.

Accessories

Part No.	Description
237524	Handles Kit
238250	Siphon Kit
238884	Return Tube Kit
17T255	Accessory Blade Kit: Blades are 15.5 inch (39.4 cm) diameter (assembled).

Dimensions

NOTE: For mounting hole locations, see [Back-Gear Mounting Hole Dimensions, page 7](#).

Models 25C483 and 25C484

UL Listed Back-Gear Drive, Model 25C483

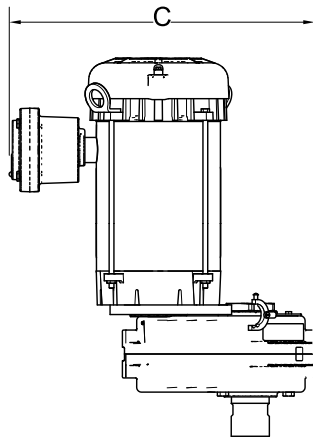

ti30704a

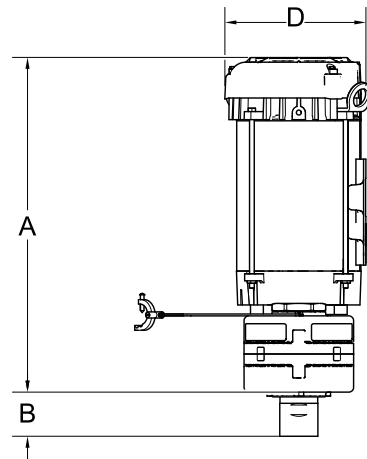

Atex Listed Back-Gear Drive, Model 25C484

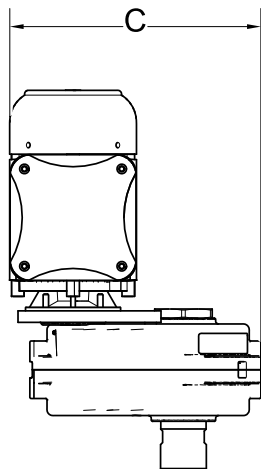

ti31417a

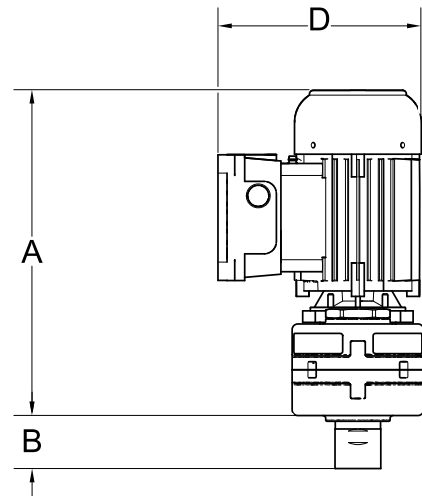

Reference	Measurement in (cm)		Reference	Measurement in (cm)	
	UL	ATEX		UL	ATEX
A	17.43 (44.3)	14.14 (35.9)	C	15.96 (40.5)	10.92 (27.7)
B	2.31 (5.9)	2.31 (5.9)	D	7.37 (18.7)	8.84 (22.5)

Dimensions

Models 25C485, 25C486, 25C487, 25C488

UL Listed Agitator with or without Siphon, Models 25C485, 25C486

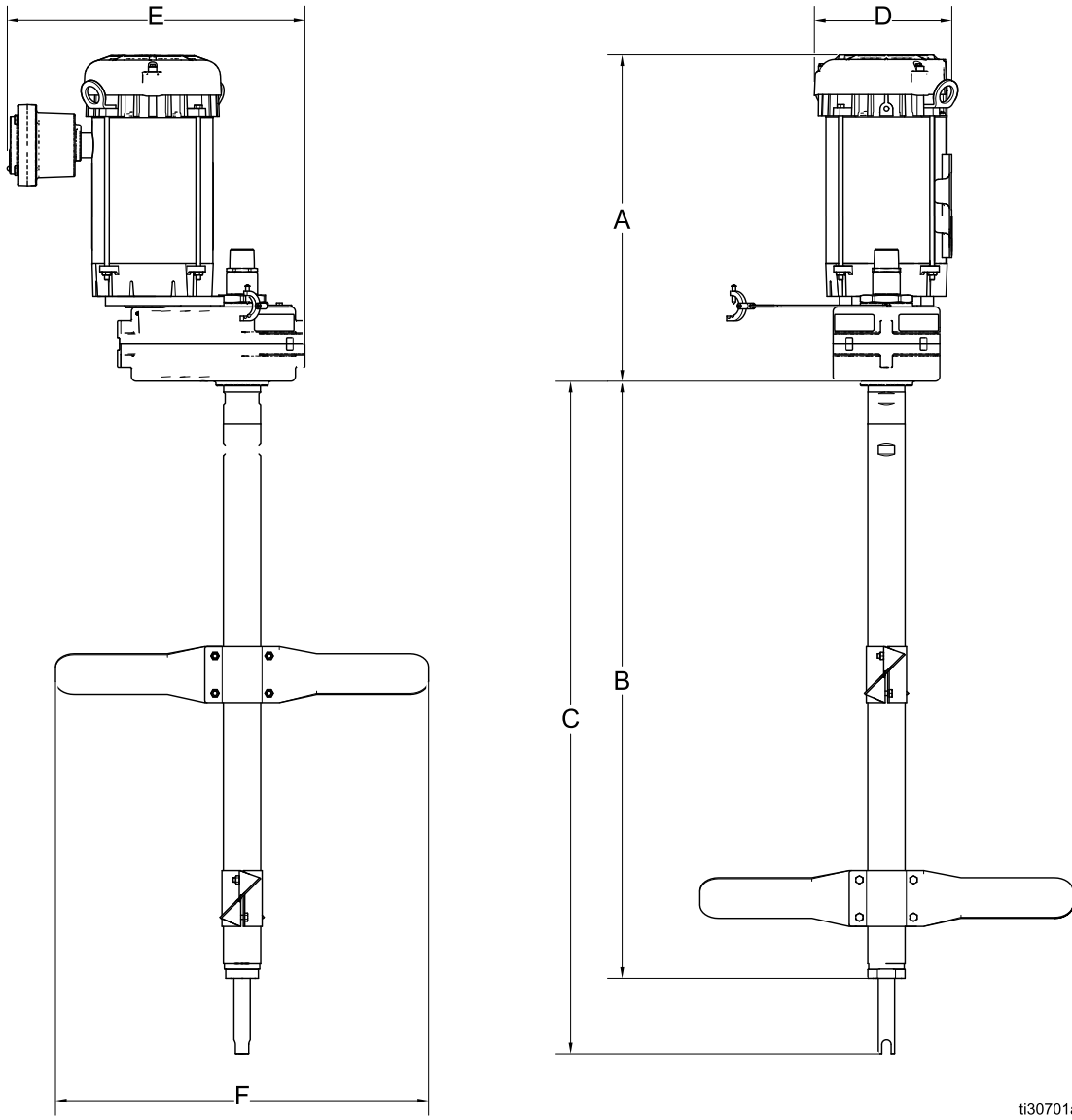

t30701a

UL Listed			
Reference	Measurement in (cm)	Reference	Measurement in (cm)
A	17.43 (44.3)	D	7.37 (18.7)
B	31.75 (80.6)	E	15.96 (40.5)
C	35.79 (90.9)	F	20.00 (50.8)

Atex Listed Agitator with or without Siphon, Models 25C487, 25C488

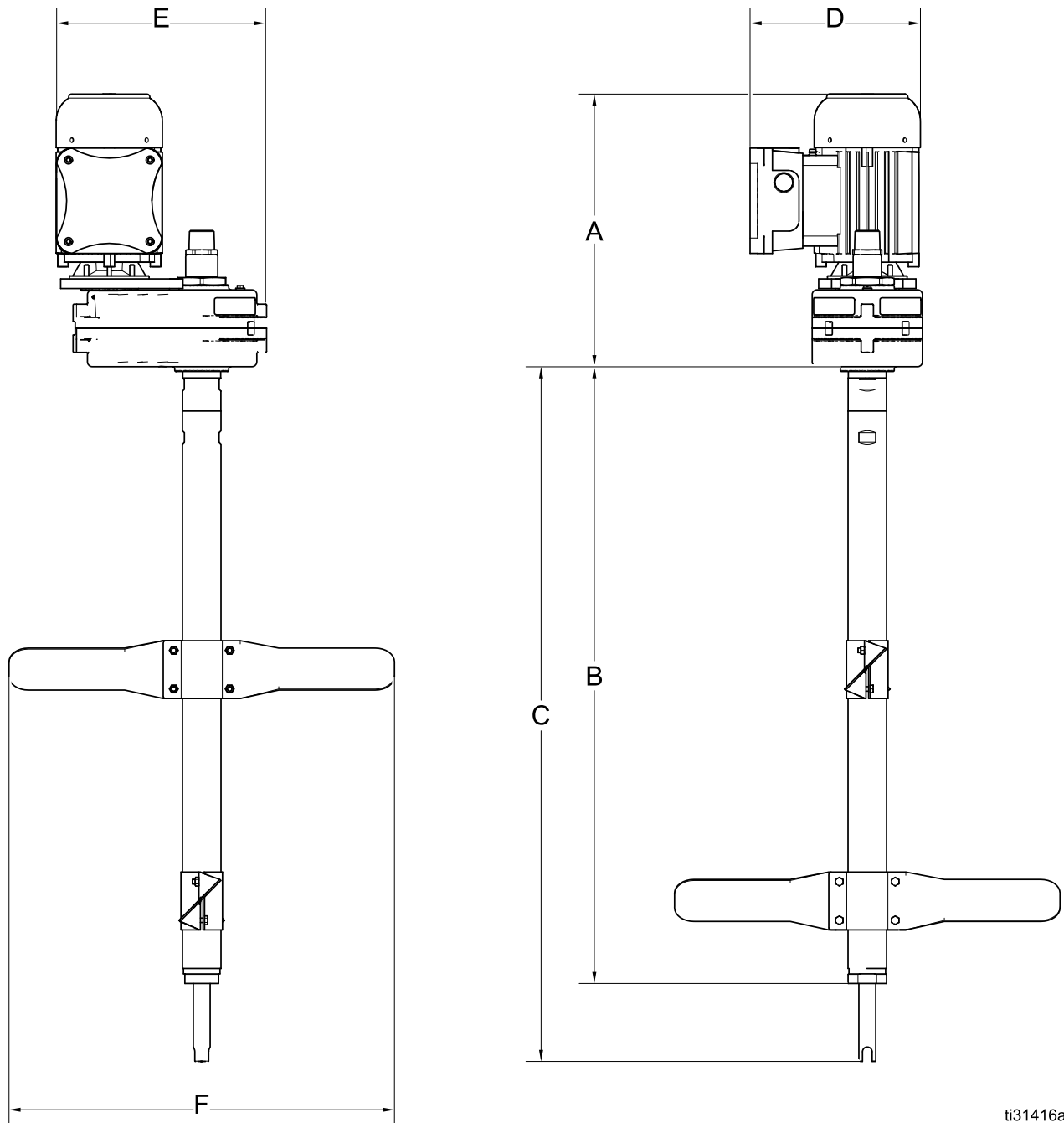

ti31416a

ATEX Listed			
Reference	Measurement in (cm)	Reference	Measurement in (cm)
A	14.14 (35.9)	D	8.84 (22.5)
B	31.75 (80.6)	E	10.92 (27.7)
C	35.79 (90.9)	F	20.00 (50.8)

Dimensions

Models 25C374, 25C451, 25C480, 25C481

UL Listed Agitator with Drum Cover and Elevator, Models 25C374, 25C451

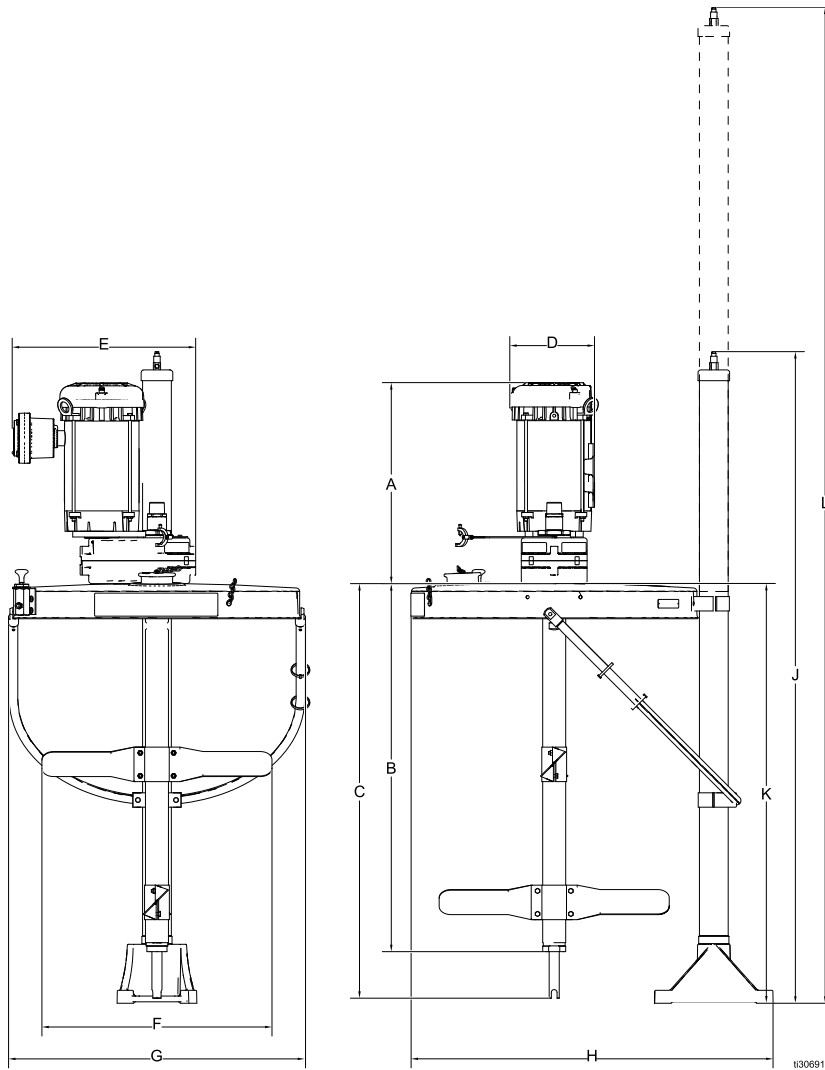

UL Listed			
Reference	Measurement in (cm)	Reference	Measurement in (cm)
A	17.43 (44.3)	G	25.68 (65.2)
B	31.75 (80.6)	H	31.50 (80.0)
C	35.79 (90.9)	J	56.65 (143.9) (down position)
D	7.37 (18.7)	K	33.60 (85.3)
E	15.96 (40.5)	L	94 (238.8) (upper position)
F	20.00 (50.8)		

Atex Listed Agitator with Drum Cover and Elevator, Models 25C480, 25C481

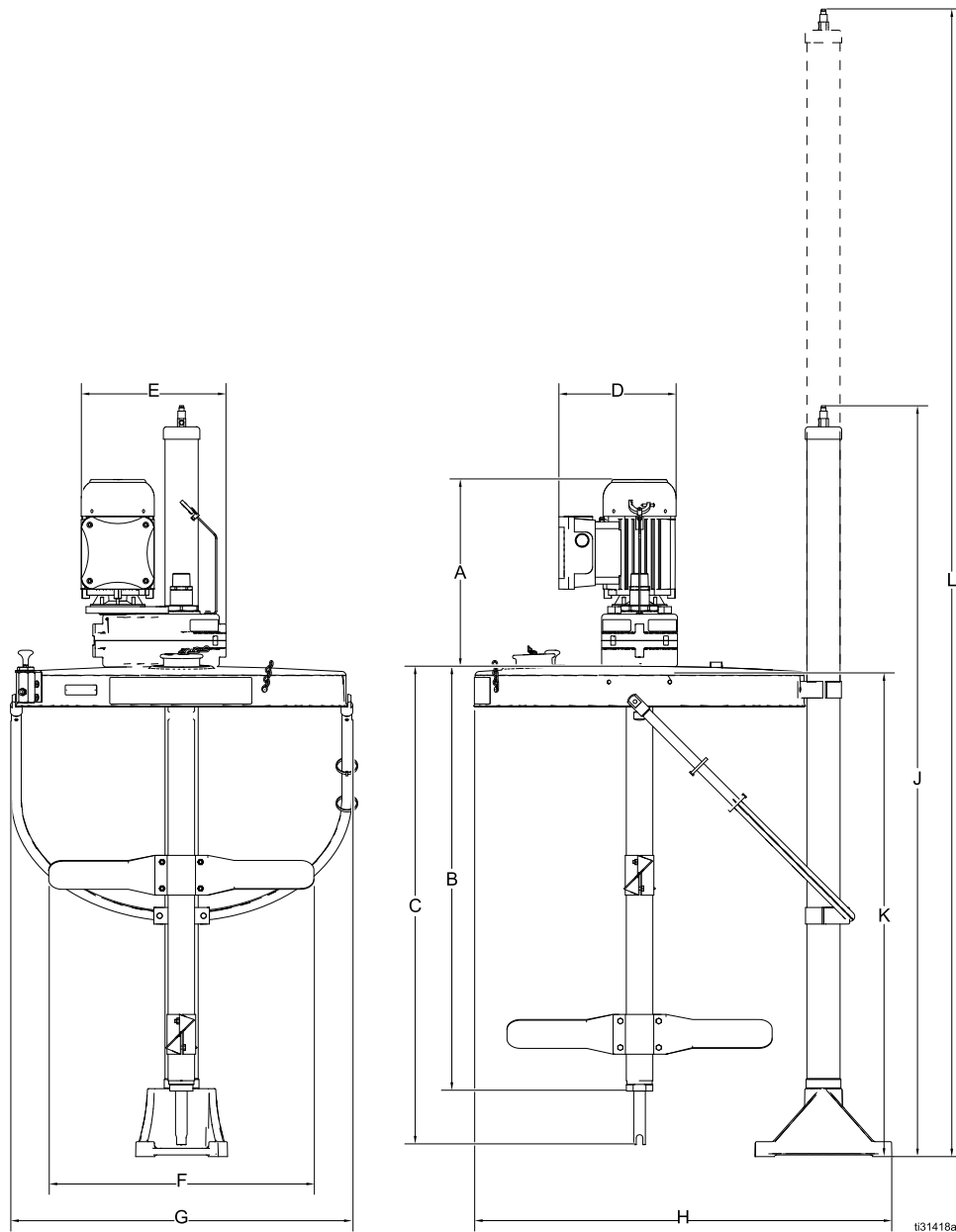

Atex Listed			
Reference	Measurement in (cm)	Reference	Measurement in (cm)
A	14.14 (35.9)	G	25.68 (65.2)
B	31.75 (80.6)	H	31.50 (80.0)
C	35.79 (90.9)	J	56.65 (143.9) (down position)
D	8.84 (22.5)	K	33.60 (85.3)
E	10.92 (27.7)	L	94 (238.8) (upper position)
F	20.00 (50.8)		

Power Usage Charts

UL Motor Power Usage Chart

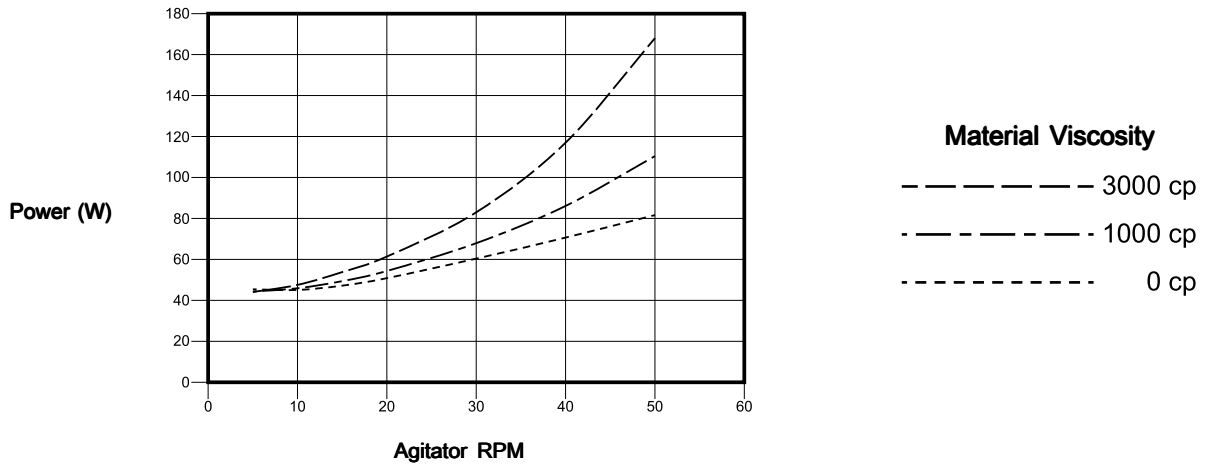

NOTE: The power measured includes the VFD power usage.

ATEX Motor Power Usage Chart

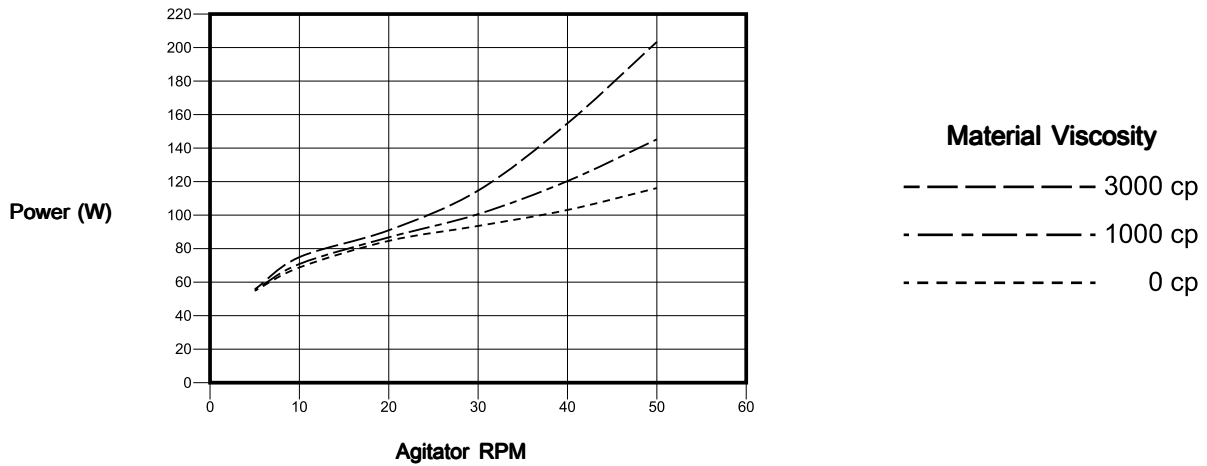

NOTE: The power measured includes the VFD power usage.

Technical Specifications

Electric Back-Gear Drum Agitators	
Motor Power	UL: 3/4 hp; ATEX: 0.37 kW
Motor Hazardous Location Approvals	UL: Explosion Proof Class 1 Group C&D Class 2 Group F&G T3C ATEX/IECEX: Ex II 2G Ex d IIB T4 Gb (see declarations included with motor)
Motor Electrical Requirements	UL: 230/460 VAC, 60 Hz, 3 Phase ATEX/IECEX: 230/400 VAC, 50 Hz, 3 Phase
Maximum Recommended Agitator Shaft Speed	50 rpm*
Minimum Recommended Motor Speed	6 hz (UL), 5 hz (ATEX)
Gear Reducer Ratio	24:1
Weight (Motor, Back-Gear, Shaft)	70 – 75 lb. (32 – 34 kg)
Agitator Blade Span	20 in. (50.8 cm)
Agitator Blade Width	3 in. (7.6 cm)
Wetted Parts	304 SST, 304/304L SST, Acetal AF , Nylon, PTFE
Siphon Tube ID	3/4 in. (19 mm)
Siphon Kit Threaded Outlet Size	1" npt
Maximum Allowable Process Fluid Temperature	158° F (70° C)
Maximum Recommended Viscosity (agitated material)	3000 cps
Noise Data (Sound Pressure Level)	Less than 75 dBA at 30 rpm
Ambient and Operating Temperature Range (limited by motor)	32° F to 104° F (0° C to 40° C)

* See [General Operation, page 11](#) for instructions on calculating agitator speed.

California Proposition 65



WARNING: This product can expose you to chemicals known to the State of California to cause cancer and birth defects or other reproductive harm. For more information, go to www.P65warnings.ca.gov.

Graco Standard Warranty

Graco warrants all equipment referenced in this document which is manufactured by Graco and bearing its name to be free from defects in material and workmanship on the date of sale to the original purchaser for use. With the exception of any special, extended, or limited warranty published by Graco, Graco will, for a period of twelve months from the date of sale, repair or replace any part of the equipment determined by Graco to be defective. This warranty applies only when the equipment is installed, operated and maintained in accordance with Graco's written recommendations.

This warranty does not cover, and Graco shall not be liable for general wear and tear, or any malfunction, damage or wear caused by faulty installation, misapplication, abrasion, corrosion, inadequate or improper maintenance, negligence, accident, tampering, or substitution of non-Graco component parts. Nor shall Graco be liable for malfunction, damage or wear caused by the incompatibility of Graco equipment with structures, accessories, equipment or materials not supplied by Graco, or the improper design, manufacture, installation, operation or maintenance of structures, accessories, equipment or materials not supplied by Graco.

This warranty is conditioned upon the prepaid return of the equipment claimed to be defective to an authorized Graco distributor for verification of the claimed defect. If the claimed defect is verified, Graco will repair or replace free of charge any defective parts. The equipment will be returned to the original purchaser transportation prepaid. If inspection of the equipment does not disclose any defect in material or workmanship, repairs will be made at a reasonable charge, which charges may include the costs of parts, labor, and transportation.

THIS WARRANTY IS EXCLUSIVE, AND IS IN LIEU OF ANY OTHER WARRANTIES, EXPRESS OR IMPLIED, INCLUDING BUT NOT LIMITED TO WARRANTY OF MERCHANTABILITY OR WARRANTY OF FITNESS FOR A PARTICULAR PURPOSE.

Graco's sole obligation and buyer's sole remedy for any breach of warranty shall be as set forth above. The buyer agrees that no other remedy (including, but not limited to, incidental or consequential damages for lost profits, lost sales, injury to person or property, or any other incidental or consequential loss) shall be available. Any action for breach of warranty must be brought within two (2) years of the date of sale.

GRACO MAKES NO WARRANTY, AND DISCLAIMS ALL IMPLIED WARRANTIES OF MERCHANTABILITY AND FITNESS FOR A PARTICULAR PURPOSE, IN CONNECTION WITH ACCESSORIES, EQUIPMENT, MATERIALS OR COMPONENTS SOLD BUT NOT MANUFACTURED BY GRACO. These items sold, but not manufactured by Graco (such as electric motors, switches, hose, etc.), are subject to the warranty, if any, of their manufacturer. Graco will provide purchaser with reasonable assistance in making any claim for breach of these warranties.

In no event will Graco be liable for indirect, incidental, special or consequential damages resulting from Graco supplying equipment hereunder, or the furnishing, performance, or use of any products or other goods sold hereto, whether due to a breach of contract, breach of warranty, the negligence of Graco, or otherwise.

FOR GRACO CANADA CUSTOMERS

The Parties acknowledge that they have required that the present document, as well as all documents, notices and legal proceedings entered into, given or instituted pursuant hereto or relating directly or indirectly hereto, be drawn up in English. Les parties reconnaissent avoir convenu que la rédaction du présente document sera en Anglais, ainsi que tous documents, avis et procédures judiciaires exécutés, donnés ou intentés, à la suite de ou en rapport, directement ou indirectement, avec les procédures concernées.

Graco Information

For the latest information about Graco products, visit www.graco.com.
For patent information, see www.graco.com/patents.

To place an order, contact your Graco Distributor or call to identify the nearest distributor.

Phone: 612-623-6921 **or Toll Free:** 1-800-328-0211 **Fax:** 612-378-3505

All written and visual data contained in this document reflects the latest product information available at the time of publication.

Graco reserves the right to make changes at any time without notice.
Original Instructions. This manual contains English. MM 3A4548

Graco Headquarters: Minneapolis
International Offices: Belgium, China, Japan, Korea

GRACO INC. AND SUBSIDIARIES • P.O. BOX 1441 • MINNEAPOLIS MN 55440-1441 • USA
Copyright 2016, Graco Inc. All Graco manufacturing locations are registered to ISO 9001.