

# GLC X Lubrication Controller

3A7031D

EN

*For controlling and monitoring an automated lubrication system. For professional use only.*

Not approved for use in explosive atmospheres or hazardous (classified) locations.

**Model: GLC X**

**Part No.: 26A814**



## Important Safety Instructions

Read all warnings and instructions in this manual and in the pump manual before using the equipment. Save these instructions.





# Table of Contents

<b>Table of Contents</b> .....	<b>2</b>	<b>Operation</b> .....	<b>17</b>
<b>Warnings</b> .....	<b>3</b>	Main Screens .....	17
<b>Component Identification</b> .....	<b>4</b>	Test Mode .....	18
(A) System LED .....	4	Alarms .....	18
(B) Low Level Status LED .....	4	Low Level Alert State .....	18
(D and E) UP and DOWN Direction Arrows ..	4	Low Level Alarm State .....	18
(F) RIGHT Direction Arrow / MANUAL RUN /		Clear Alarm Buzzer .....	18
ENTER .....	4	Clear Low Level Alarm .....	18
(G) LEFT Direction Arrow / Reset .....	4	Alarm Types .....	19
<b>Typical Installation</b> .....	<b>6</b>	<b>Maintenance</b> .....	<b>21</b>
<b>Installation</b> .....	<b>7</b>	Recycling and Disposal at End of Life .....	21
Mounting .....	7	<b>Troubleshooting</b> .....	<b>22</b>
Wiring .....	7	<b>Accessories</b> .....	<b>23</b>
<b>System Configuration</b> .....	<b>8</b>	<b>Dimensions</b> .....	<b>23</b>
Injector System .....	8	<b>Mounting Hole Layout</b> .....	<b>24</b>
Divider Valve .....	9	<b>Technical Specifications</b> .....	<b>25</b>
Wiring Diagram .....	10	<b>Compliance</b> .....	<b>26</b>
<b>Wiring Key</b> .....	<b>10</b>	Radio Frequency Approvals .....	26
<b>Sensor Wiring Configurations</b> .....	<b>11</b>	California Proposition 65 .....	27
Dry Contact Switch .....	11	<b>Graco Standard Warranty</b> .....	<b>28</b>
Analog Sensor .....	11		
Source/PNP Switch (2 or 3 Wire Type) .....	11		
<b>Setup</b> .....	<b>12</b>		
Navigating Setup and Data Entry .....	12		
Change Settings .....	12		
Mode .....	12		
End On .....	13		
Low Level .....	13		
Paddle .....	13		
Switch .....	14		
Sensor .....	14		
Lock .....	14		
Enable a Lock out PIN .....	14		
Entering a PIN .....	14		
Start Up .....	14		
Output 2 .....	14		
System .....	14		
Date and Time .....	14		
Additional Advanced Features .....	15		
Program Settings .....	16		

# Warnings

The following warnings are for the set up, use, grounding, maintenance, and repair of this equipment. The exclamation point symbol alerts you to a general warning and the hazard symbols refer to procedure-specific risks. When these symbols appear in the body of this manual or on warning labels, refer back to these Warnings. Product-specific hazard symbols and warnings not covered in this section may appear throughout the body of this manual where applicable.

 <h1 style="margin: 0;">WARNING</h1>	
 	<p><b>EQUIPMENT MISUSE HAZARD</b> Misuse can cause death or serious injury.</p> <ul style="list-style-type: none"> <li>• Do not operate the unit when fatigued or under the influence of drugs or alcohol.</li> <li>• Do not exceed the maximum working pressure or temperature rating of the lowest rated system component. See <b>Technical Specifications</b> in all equipment manuals.</li> <li>• Use fluids and solvents that are compatible with equipment wetted parts. See <b>Technical Specifications</b> in all equipment manuals. Read fluid and solvent manufacturer's warnings. For complete information about your material, request Safety Data Sheets (SDSs) from distributor or retailer.</li> <li>• Do not leave the work area while equipment is energized or under pressure.</li> <li>• Turn off all equipment and follow the <b>Pressure Relief Procedure</b> found in the related pump manual when equipment is not in use.</li> <li>• Check equipment daily. Repair or replace worn or damaged parts immediately with genuine manufacturer's replacement parts only.</li> <li>• Do not alter or modify equipment. Alterations or modifications may void agency approvals and create safety hazards.</li> <li>• Make sure all equipment is rated and approved for the environment in which you are using it.</li> <li>• Use equipment only for its intended purpose. Call your distributor for information.</li> <li>• Route hoses and cables away from traffic areas, sharp edges, moving parts, and hot surfaces.</li> <li>• Do not kink or over bend hoses or use hoses to pull equipment.</li> <li>• Keep children and animals away from work area.</li> <li>• Comply with all applicable safety regulations.</li> </ul>

# Component Identification

**NOTICE**

To prevent damage to soft key buttons, do not press the buttons with sharp objects such as pens, plastic cards, screwdrivers, or fingernails.

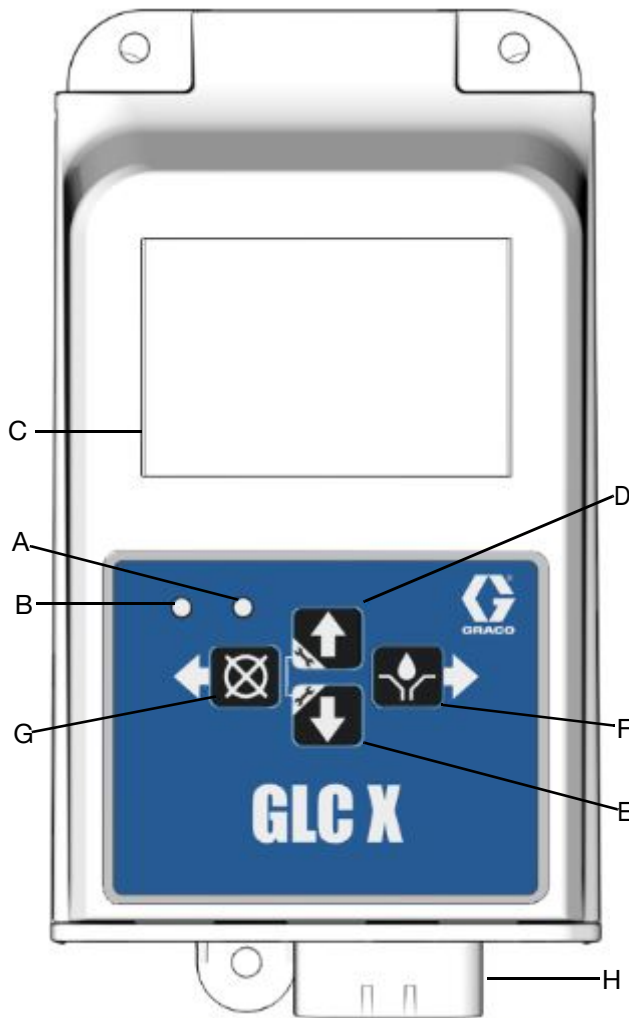

**FIG. 1: GLC X Controller Front**

- A System LED
- B Low Level Status LED
- C Display
- D UP Arrow
- E DOWN Arrow
- F RIGHT Arrow / ENTER
- G LEFT Arrow / Reset
- H Connector

## (A) System LED

Light	Status
Red (solid)	Normal and ON
Orange (solid)	Controller is in system SETUP and lubrication program is paused
Red (flashing)	System is in alarm

## (B) Low Level Status LED

Light	Status
Orange (solid)	Low level alert
Flashing	Another alarm in addition to a low level alert

## (D and E) UP and DOWN Direction Arrows

Press and hold both the UP and DOWN ARROW keys simultaneously for 3 seconds to enter SETUP.

## (F) RIGHT Direction Arrow / MANUAL RUN / ENTER

In SETUP the RIGHT Arrow saves the entry or selects a menu choice.

When not in SETUP, the RIGHT Arrow starts the pump for one complete lubrication event.

Holding down both the RIGHT Arrow and the LEFT Arrow simultaneously for 3 seconds starts TEST MODE.

## (G) LEFT Direction Arrow / Reset

In SETUP the LEFT Arrow moves the cursor in the display one field to the left. It also navigates back to the previous screen and cancels parameter change.

If the pump is lubricating, pressing this button cancels the event and the pump stops lubricating.

In ALARM, press the LEFT Arrow once to clear the buzzer. Press and hold for 3 seconds to clear the alarm. For more information, see **Alarms**, page 18.

Holding down both the RIGHT Arrow and the LEFT Arrow simultaneously for 3 seconds starts TEST MODE.

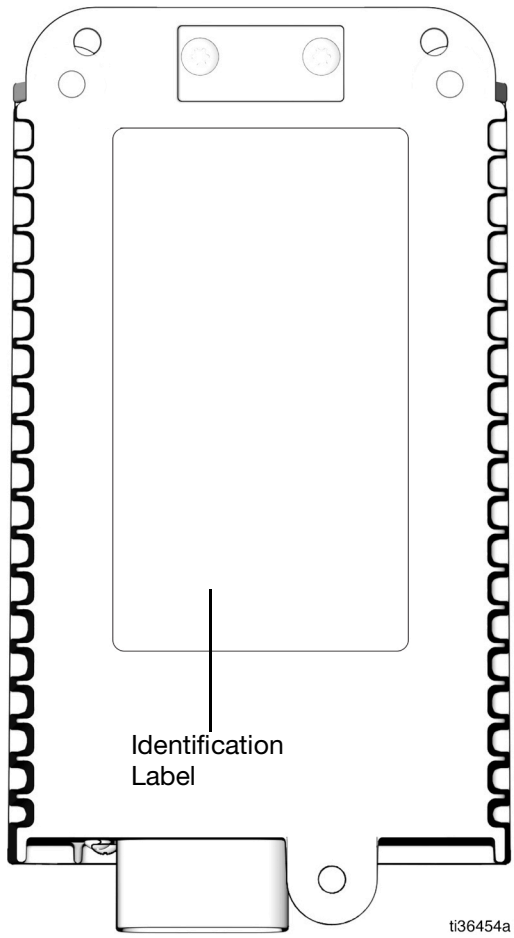

**FIG. 2: GLC X Controller Back**

# Typical Installation

The installation shown in FIG. 3 is only a guide for selecting and installing system components.

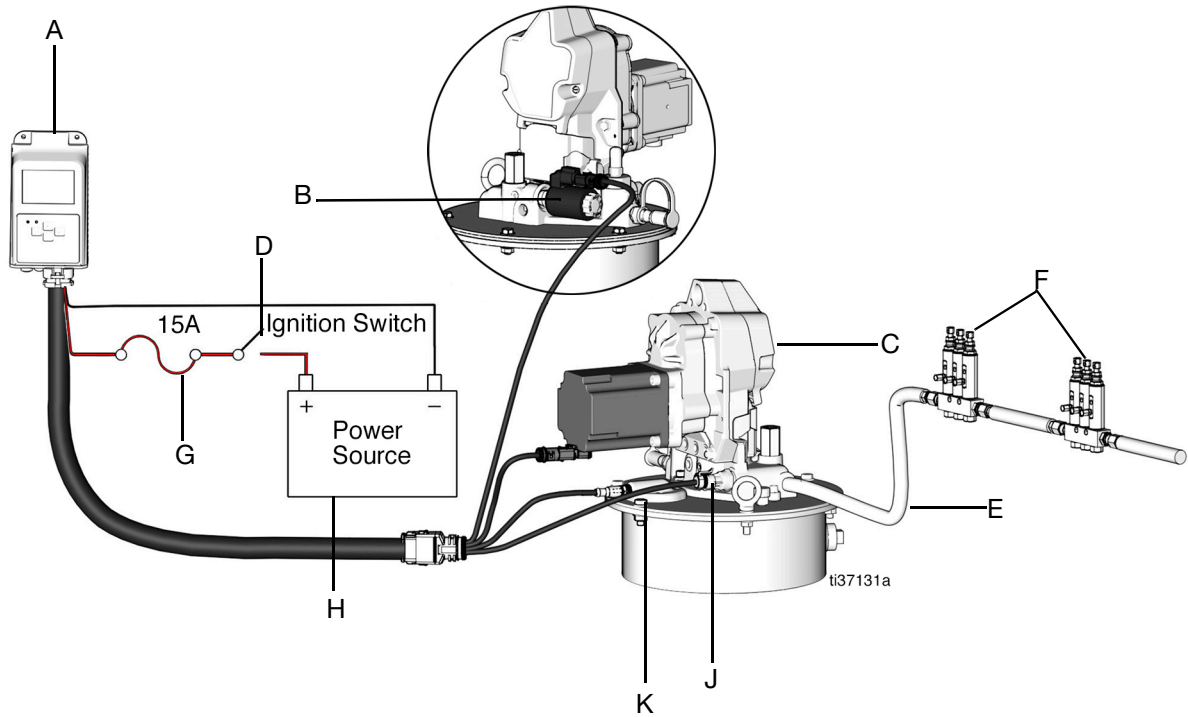

**FIG. 3: Typical Installation**

**Key:**

- A Lubrication Controller
- B Solenoid Valve
- C Pump Module
- D Ignition Switch
- E High Pressure Lubricant Supply Lines
- F Injector Banks
- G In-line 15A Fuse
- H Power Source
- J Pressure Sensor
- K Level Sensor

# Installation

<p><b>AUTOMATIC SYSTEM ACTIVATION HAZARD</b></p> <p>Unexpected activation of the pump lubrication system could result in serious injury, including skin injection and amputation.</p> <p>The Lubrication Controller has an automatic timer that activates the pump lubrication system when power is connected or when exiting this device's programming function. Before you install or remove the Lubrication Controller from the system, disconnect and isolate all system power supplies and relieve pressure for all system components.</p>			

**NOTICE**

Pre-drill and use only designated mounting holes in Lubrication Controller box. Failure to use designated mounting holes can cause circuit board damage.

## Mounting

1. Select a flat surface to install the Lubrication Controller. Drill mounting holes, refer to **Mounting Hole Layout**, page 24.
2. Align the junction box with the pre-drilled holes (FIG. 4). Secure the junction box to the mounting surface with three screws (not provided).

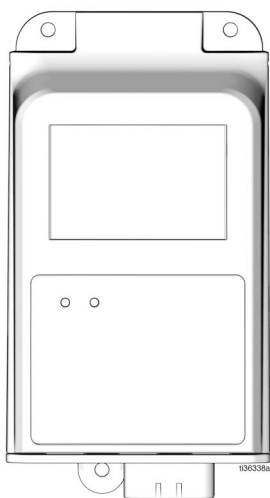

**FIG. 4 Pre-drilled holes**

## Wiring

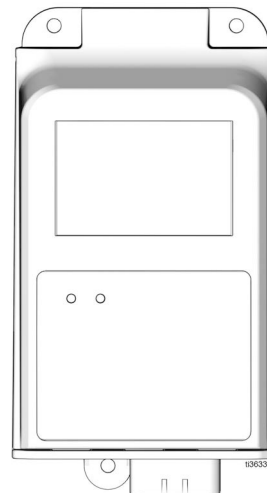

**FIG. 5: Lubrication Controller Connector**

- Output voltage is the same as the input voltage.

**NOTICE**

The pump is designed for 10 A. The auxiliary outputs are designed for 10 A.

The entire system, however, is only capable of delivering a total of 15 A.

Therefore, if the pump is a 10 A load, the sensors and auxiliary output must not exceed 5 A.

- The Lubrication Controller is designed to power a pump or to provide an enable signal to a pump.
- **Sensor Wiring Configurations** are located on page 11.
- **Wiring Diagram** is located on page 10.

# System Configuration

To determine the required configurations needed, refer to the following pages.

## Injector System

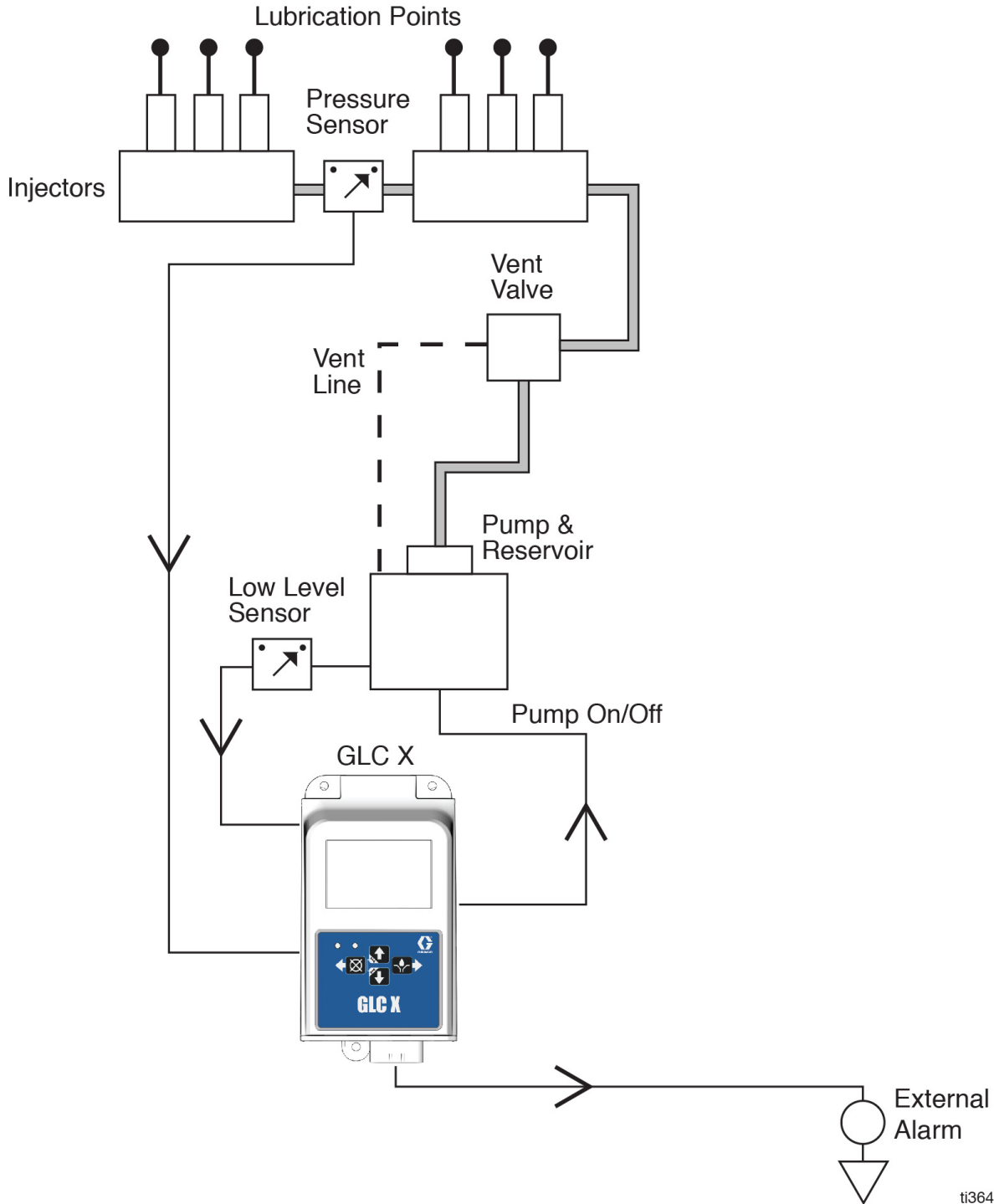
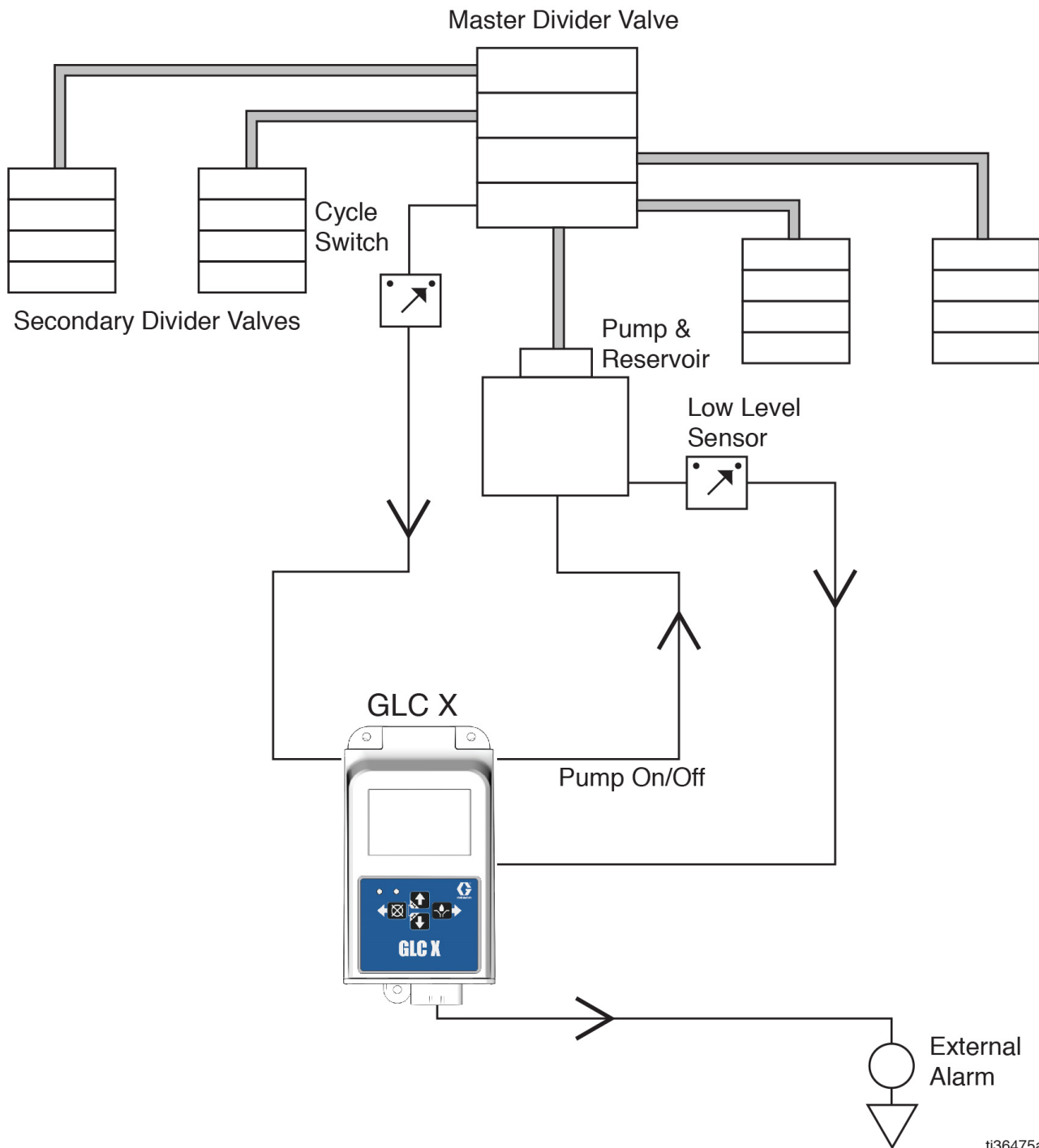

FIG. 6 Injector System Configuration



# Divider Valve



ti36475a

**FIG. 7 Divider Valve System Configuration**

## Wiring Diagram

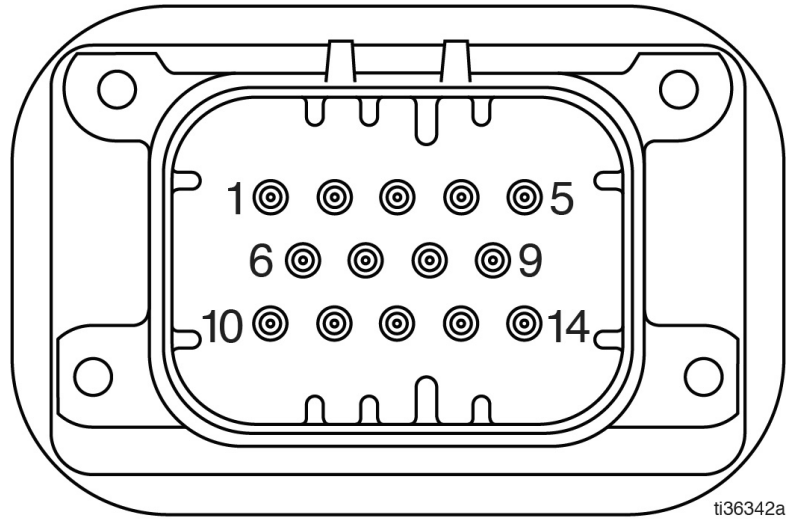

ti36342a

**Fig. 8: Wiring Diagram**

### Wiring Key

Pin	Description	Polarity
1	Pump / Motor	+
2	Auxiliary / Alarm	+
3	Pump / Motor ground	-
4	Sensor power 1	+
5	Sensor power 2	+
6	Voltage source	+
7	Auxiliary / Alarm ground	-
8	Input 2 ground	-
9	Input 2 (LOW LEVEL)	Input
10	Voltage source ground	-
11	Input 3 (CYCLE)	Input
12	Input 4 (MACHINE COUNT/PADDLE)*	Input
13	Input 1 ground	-
14	Input 1 (PRESSURE)	Input

\*When used with a Graco G1 Standard or Graco G3 Standard, the pump's low level output must be connected to Pin 12. The controller must also be programmed to Paddle Low Level.

# Sensor Wiring Configurations

## Dry Contact Switch

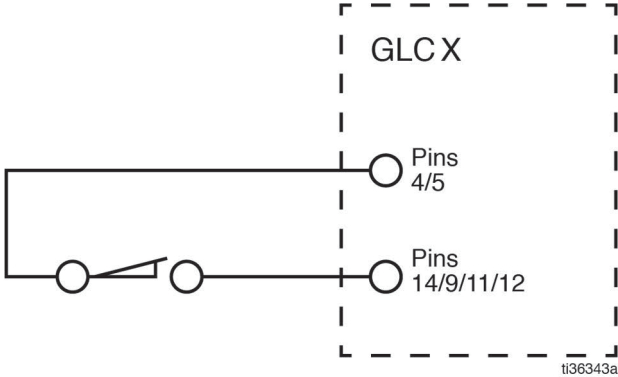

FIG. 9

## Source/PNP Switch (2 or 3 Wire Type)

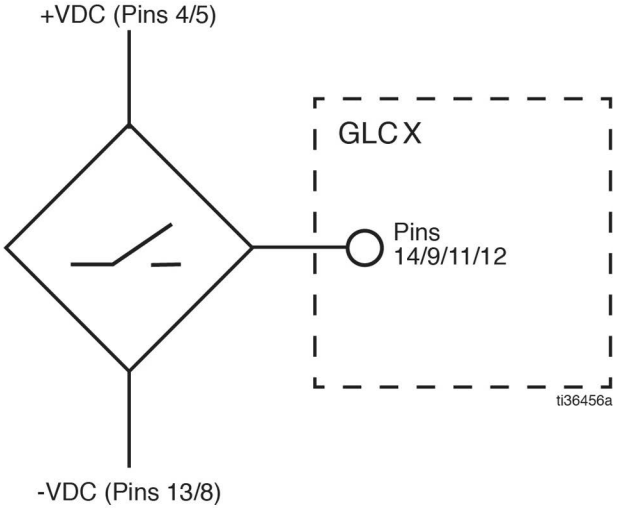

FIG. 11

## Analog Sensor

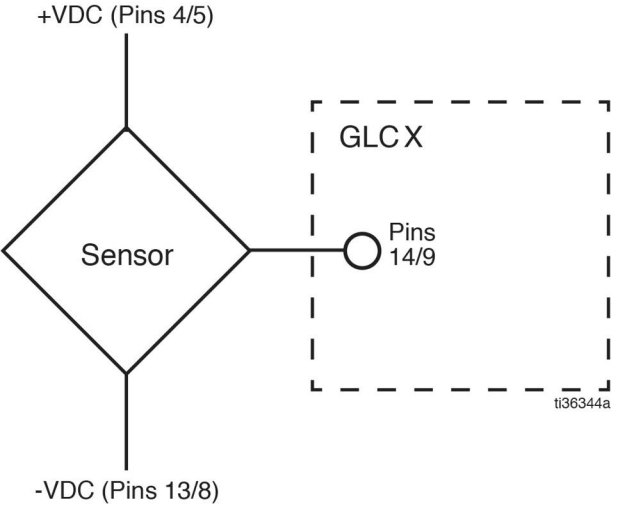

FIG. 10

# Setup

Download the free Graco Auto Lube App to your smart phone, now available on Apple® App Store® and on Google Play™.

## Navigating Setup and Data Entry

UP and DOWN Arrows:

- Press both the UP and DOWN Arrows simultaneously for 3 seconds to enter SETUP.



- Use the UP and DOWN Arrows to navigate screens in the up or down direction.



- Use these buttons to adjust parameters and data values.

RIGHT Arrow:

- Use this button to move the cursor to the right or to select menu items.
- Use this button to save any parameter changes.



LEFT Arrow:

- Use this button to move the cursor to the left.
- Use this button to navigate to the previous screen. This cancels any parameter change made.



## Change Settings

Press both the UP and DOWN Arrow buttons simultaneously for three seconds to enter SETUP and to change settings.

Note: Setting changes are not saved until Accept is selected.

While in SETUP, if a button is not pushed for 1 minute the Lubrication Controller returns to idle.

## Mode

Choose either Interval or End On, but both must be set up before the Lubrication Controller will be configured for your application.

### Interval

Configures how frequently the GLC X lubricates the product.

- Select either Timer Interval or Machine Count Interval.

### Timer Interval

This sets up how frequently lubrication occurs.

- Interval: defines the time between lubrication events.

The idle time shows interval time minus the lubrication time. If the interval time is 30 minutes and the lubrication time is 1 minute, then after a lubrication event the idle time is 29 minutes. The lubrication events will then be spaced by 30 minutes (Interval Time).

### Machine Count Interval

This configures the device to wait for a specific number of machine actions between lubrication events.

The actions must be presented to the device as a machine count input. This is a digital signal input, similar to a proximity switch that would be used for Cycle mode.

- Timeout Option: enables/disables an interval backup timeout.
- Interval: when timeout is enabled, this feature defines the backup timeout for machine count.
- Timeout Action: select the action taken (either Lube or Alarm) when a machine count timeout occurs.

Lube: the lubrication event starts if the target machine counts do not occur within the user defined time.

Alarm: an alarm occurs if the targeted machine counts do not occur within the user defined time.

## End On

Configures when a lubrication event ends. Selects the method the controller uses to transition from lubrication to idle.

### End on, Pressure Sensor

The lubrication event ends when the system reaches a specific pressure. This is commonly used with Single Line Parallel (Injector) systems using a pressure switch.

- Alarm: defines maximum time to reach target pressure.
- Type: select the type of pressure sensor output: 0.5-4.5 V, 0-5V, 1-5 V, 0-10 V, and 4-20 mA.
- Units: select the units label to display with the pressure measurement: kPa, Percent, PSI, and bar.
- Full Scale: the maximum sensor output reading. For example, if a 0-10 V sensor is 5000 psi at full scale, then 10 V = 5000 psi.
- Threshold: the target pressure the system must reach to end the lubrication event.

**For Version 1.02.002 and earlier:** 0.5-4.5V is not available. Update to the latest version using the Graco Auto Lube App.

### End on, Pressure Switch

The lubrication event ends when the system reaches a specific pressure. This is commonly used with Single Line Parallel (Injector) systems using a pressure switch.

The pressure switch must be physically set to the appropriate target pressure.

- Alarm Timeout: defines the maximum allowable time to reach target pressure.

### End on, Cycles

The lubrication event ends after a number of pulsed inputs from a cycle counter. This is commonly used with Series Progressive (Divider Block) systems.

- Count: defines the number of cycle inputs required per lubrication event.

- Alarm Timeout: defines the maximum allowable time to accumulate cycle counts.
- Solenoid Failure Alarm: if enabled, an alarm displays if cycle inputs are detected during idle time.

### End on, Timer

The lubrication event ends after a specified amount of time.

- Timeout: defines the amount of time that the system is lubricating.

## Low Level

The pump stops lubricating when low level is detected. To define low level, enter SETUP, select low level, and then select Type: Paddle, Switch, or Sensor.

### Paddle

Used with “paddle-style” low level sensors, e.g., Graco G3 grease units.

- Alert: Enable/disable low level Alert.
  - Alert Count: Number of low level triggers to cause Alert. Recommended setting for Alert Count is 10 triggers.
  - Alarm: Enable/disable low level Alarm.
  - Alarm Count: Number of low level triggers to cause alarm. Recommended setting for Alarm Count is 80 triggers.
- For Version 1.02.002 and earlier:** Enable and Count settings are combined for Alert/Alarm. Disable the Low Level Alert or Alarm by setting the threshold to zero. Update to the latest version using the Graco Auto Lube App.
- Auto-Clear: when in a Low Level Alarm state, the controller attempts to lubricate automatically upon powering up.
  - If within 30 seconds of entering run mode a low level trigger is not detected, the count resets to 0.

**Note:** The Low Level paddle uses pin 12 of the GLC X controller. Review **Wiring Key**, page 10.

## Switch

Defines the low level input as a dry-contact (or source style) switch that triggers when a low level is detected.

- **Type:** defines the actions upon low level detection.  
  
**Alert:** the low level LED turns on. Output two turns on.  
  
**Alarm:** enters an alarm state and stops lubricating. The low level LED turns on and the screen shows an alarm screen.

## Sensor

Defines the low level input as a continuous monitoring sensor. The level is displayed as a percentage (%).

- **Sensor Type:** select the type of level sensor output: 0,5-4,5V, 0-5 V, 1-5 V, 0-10 V, and 4-20 mA.
- **Alert:** Enables a low level Alert. In Alert, the low level LED turns on. Output 2 turns on.
- **Alert %:** the level that triggers a low level Alert.
- **Alarm:** Enables a low level Alarm. In Alarm, the system stops lubrication. The low level LED flashes, and the screen shows an alarm screen.
- **Alarm %:** The level that triggers a low level Alarm.

**For Version 1.02.002 and earlier:** Disable the Low Level Alert or Alarm by setting the threshold to zero.

## Lock

The controller does not require a PIN to access the programming features of the unit. However, an option for adding PIN lock out is available.

### Enable a Lock out PIN

Navigate to the menu item lock.

- **Lock:** toggles on/off Lock out PIN protection.
- **PIN:** enter a 4 digit code to unlock the device.

If a lockout PIN is enabled, a PIN must be used to change settings.

## Entering a PIN

When entering SETUP, the PIN entry screen appears with the first digit highlighted. Use the arrow buttons to enter the PIN.

After entering the last digit, press the RIGHT ARROW button to accept the PIN.

If the PIN is correct, the device enters SETUP.

If the PIN is incorrect, the device returns to the main screen.

## Start Up

Navigate to the menu item start up.

- **Pre-lube:** configures the GLC X to start a lubrication event once powered on.
- **Delay:** enables a delay between when the device is powered on and when the controller resumes.
  - **Delay Time:** if applicable, configures the delay time.

## Output 2

Assign as alarm output or vent valve output.

- **Alarm & Alert:** active on Alarm or Alert.
- **Alarm:** active on Alarms only.
- **Alert:** active on Alerts only.
- **Vent Valve:** active during a lubrication event.

## System

In addition to date and time, enabling Bluetooth® and disabling an audible alarm are found under this heading.

### Date and Time

Navigate to the menu item time.

- **Date:** defines today's date.
- **Time:** defines the current time. This clock runs on a 24 hour clock. (9 a.m. = 9, 2 p.m. = 14)

## Additional Advanced Features

Advanced features are accessible through the mobile app, gracoautolube, available for Android<sup>®</sup> and Apple<sup>®</sup> devices in the app store.

- Generic alarm input: assign unused input to trigger an alarm.
- Pulsed output: pulses pump output during lubrication event. Typically used with single stroke pumps.

## Program Settings

Feature	Description	Modes of Operation Maximum/Minimum and Additional Comments
<b>Interval</b> , page 12	Mode	Timer Machine Count
	Machine Count	1 to 10,000
	Machine Count Options	<ul style="list-style-type: none"> <li>- Action to start lubrication or alarm when timeout expires</li> <li>- Enable a backup timeout</li> </ul>
	Interval	HH:MM (00:01 to 99:59) Defines time between lubrication events
<b>End On</b> , page 13	Mode	Timer, Pressure Switch, Pressure Sensor, Cycle
	Timeout	HH:MM:SS (00:00:10 to 03:00:00)
	Pressure Type	0-5V, 0-10V, 1-5V, 4-20mA
	Pressure Sensor Units	PSI, kPa, bar, percent
	Pressure Sensor Full Scale	1 to 20,000 Requires: Threshold is less than or equal to Full Scale
	Pressure Sensor Threshold	1 to 20,000 Requires: Threshold is less than or equal to Full Scale
	Pressure Sensor Target	1 to 20,000 Requires: Threshold is less than or equal to Full Scale
	Cycles	0 to 100
	Cycle Option Solenoid Alarm	Enables alarm when cycles are detected during idle time
<b>Low Level</b> , page 13	Low Level Type	Paddle, Low Level Switch, Low Level Sensor
	Paddle Low Level Alert Threshold	Recommended: 10 00 to 99 Requires Alarm > Alert Setting of zero disables low level alert threshold
	Paddle Low Level Alarm Threshold	Recommend: 80 00 to 99 Requires: Alarm > Alert Setting of zero disables low level alarm threshold
	Paddle Alarm Auto-Clear	Enables a feature that will automatically clear a low level alarm and start a lubrication event to check if the reservoir is still empty
	Level Switch Type	Sets low level behavior as low level Alert or low level alarm
	Sensor Type	0-5V, 0-10V, 1-5V, 4-20mA
	Sensor Alert Threshold	0 - 100 Requires: Alarm < Alert Setting of zero disables low level alert threshold
Sensor Alarm Threshold	0 - 100 Requires: Alarm < Alert Setting of zero disables low level alarm threshold	
<b>Start Up</b> , page 14	Delay Time	MM:SS (00:01 to 59:59)
<b>Output 2</b> , page 14	Output Type	Activated pm Alarm, only, Alert only, Alarm and Alerts, or to close Vent Valve
<b>System</b> , page 14	Date	Month: 1 - 12 Day: 1 - 31 Year: 18 - 99
	Time	00:00:00 to 23:59:59 24-hour time



# Operation

## Main Screens

Refer to the following illustrations for examples of typical operation screens.

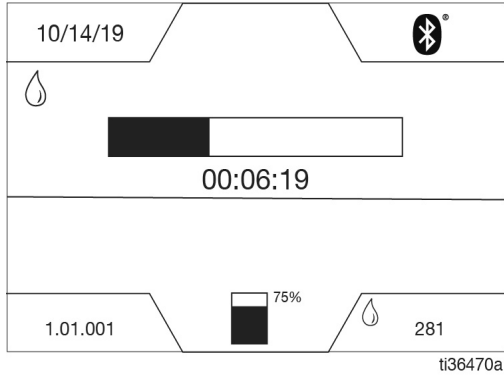

**FIG. 12 Lubrication Event: Pressure Switch**

ti36470a

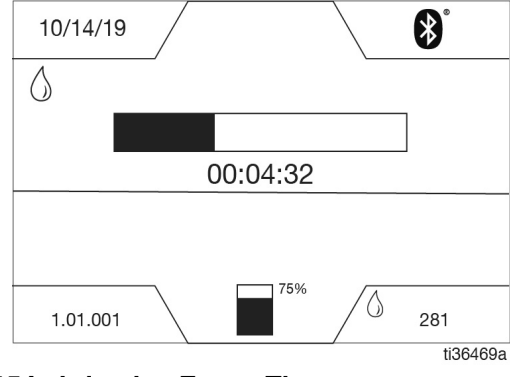

**FIG. 15 Lubrication Event: Time**

ti36469a

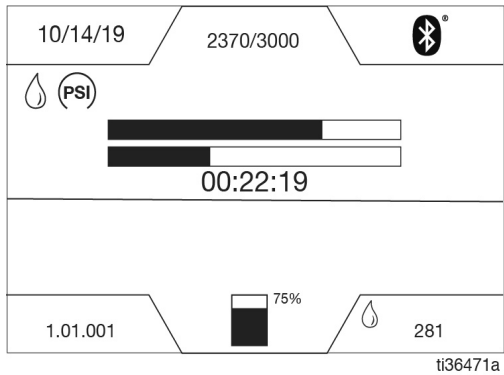

**FIG. 13 Lubrication Event: Pressure Sensor**

ti36471a

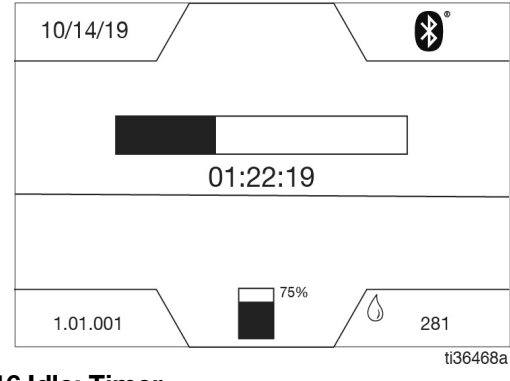

**FIG. 16 Idle: Timer**

ti36468a

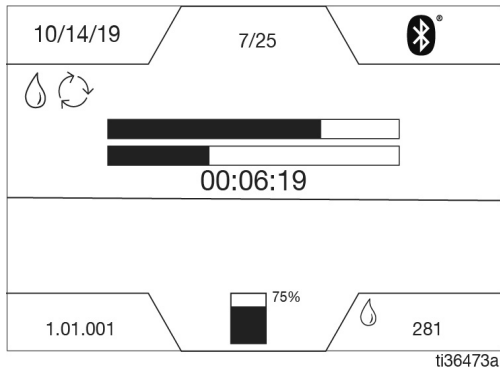

**FIG. 14 Lubrication Event: Cycle**

ti36473a

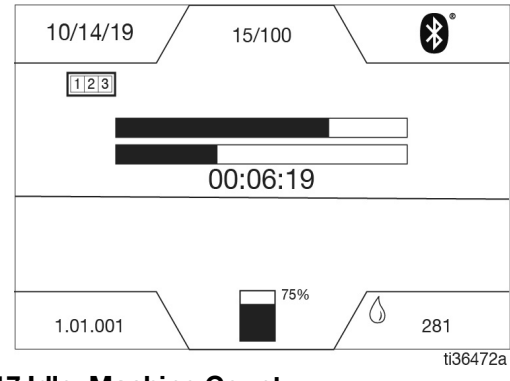

**FIG. 17 Idle: Machine Count**

ti36472a

## Test Mode

On the main screen press and hold both the LEFT and RIGHT ARROWS simultaneously for 3 seconds to enter TEST MODE.

While in TEST MODE the controller:

End Configuration	ON time (min)	OFF time (min)
Pressure System	7	1
Timer System	2	1
Cycle System	2	1

TEST MODE ends after 10 lubrication events. TEST MODE is canceled by pressing the LEFT ARROW button.

## Alarms

During an alarm:

- Pump operation is immediately disabled
- The system LED flashes red
- An alarm screen displays
- An audible alarm sounds
- Output 2 turns on

Press the reset button (LEFT ARROW button) once to clear the buzzer.

Press and hold the reset button for 3 seconds to clear the alarm and switch the controller to idle.



## Low Level Alert State

- Run mode continues
- Low level LED is on (B, FIG. 1)
- System LED is on (A, FIG. 1)
- Output 2 in ON

## Low Level Alarm State

- Pump operation is immediately disabled
- Low level LED is on (B, FIG. 1)
- System LED flashes red (A, FIG. 1)
- Output 2 is ON
- Audible alarm
- Screen shows alarm information

## Clear Alarm Buzzer

Press reset (LEFT ARROW button) to silence the buzzer.

The buzzer sounds again after 4 hours if the low level condition is not resolved. The buzzer also sounds again when power is cycled.





## Clear Low Level Alarm

Filling the reservoir resolves a low level sensor and low level switch condition, and the level sensor and level switch will self-clear.

Hold the reset button for at least 5 seconds to remove the low level alarm from the controller.

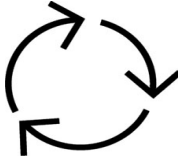
For more details regarding a specific alarm, see **Alarm Types**, page 19 and **Troubleshooting**, page 22.

## Alarm Types

Alarm ID	Alarm Type	Alarm Icon	Cause	Solution
A13	Level Empty		There is a low lubricant level	Fill the reservoir.
A11	Cycle Timeout		The time out expired before receiving programmed number of cycle counts.	<p>Inspect the lubrication system for broken or plugged lines.</p> <p>Confirm that the pump is operating correctly.</p> <p>Inspect the cycle and proximity switch and wiring.</p> <p>Confirm that sufficient time was programmed for the environmental conditions (e.g. slow system response in cold temperatures).</p> <p>Confirm that the programming is correct.</p>
A15	Pressure Timeout		The time out expired prior to receiving pressure switch input.	<p>Inspect the lubrication system for broken or plugged lines.</p> <p>Confirm that the pump is operating correctly.</p> <p>Confirm that the vent valve is operating correctly</p> <p>Inspect the wiring, pressure, switch, and sensor.</p> <p>Confirm that sufficient time was programmed for the environmental conditions (e.g. slow system response in cold temperatures).</p> <p>Confirm that the programming is correct.</p>
A16	Pressure not vented		<p>The vent valve failed to relieve pressure to the system.</p> <p>Pressure Switch is showing as a closed switch, or the sensor is above the pressure threshold when the lubrication cycle started.</p>	<p>Fix the cabling to the vent valve.</p> <p>Ensure that enough power is being delivered to the vent valve.</p> <p>Confirm that the controller settings are correct.</p> <p>Replace the vent valve if it is broken.</p> <p>Inspect the wiring, pressure switch and sensor, and check for short circuits.</p> <p>Confirm that the controller settings are correct.</p>
A19 (Pin 2) A20 (Pin 1) A21 (Pin 4) A22 (Pin 5)	Output Overcurrent		Output load is drawing too much current	<p>Inspect the wiring.</p> <p>Confirm that the pump is operating correctly and not drawing more current than expected.</p>

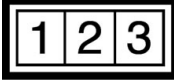
Alarm ID	Alarm Type	Alarm Icon	Cause	Solution
A17 (INPUT 1) A18 (INPUT 2)	Sensor Fault		Sensor input is out of range for given type	Inspect the sensor and wiring. Confirm that the programming is correct.
A14	Machine Count Timeout		The machine use is low. The cabling to machine count is broken.	Confirm that the controller settings are correct for machine usage.
A23	Solenoid Failure	No Symbol	The solenoid valve used to control the lubrication flow has failed.	Replace the solenoid valve used to control lubrication flow.
A12	Generic Input	No Symbol	The user defined input is active and requires attention.	Resolve the system issue. Clear the alarm when the system issue is resolved.

# Maintenance

## Recycling and Disposal at End of Life

At the end of the product's useful life, dismantle and recycle it in a responsible manner.

Dismantle and recycle:

- Remove motors, circuit boards, LCDs (liquid crystal displays), and other electronic components. Recycle according to applicable regulations.
- Do not dispose of electronic components with household or commercial waste.



- Deliver remaining product to a recycling facility.

# Troubleshooting



Follow the **Pressure Relief Procedure** detailed in the pump manual before working on the lubrication system, pump, or lubrication lines.

Problem	Cause	Solution
Display or LED does not come on	Incorrect or loose wiring	Refer to <b>Installation</b> , page 7.
	Input voltage is out of range	Confirm that the power source is between 9 and 30 VDC.
	Tripped external fuse	Confirm that none of the devices or wiring connected to the controller are causing a short circuit connection. If necessary, replace fuse.
Pump is not running during lubrication event	Incorrect or loose wiring	Confirm current is being delivered to the pump during a lubrication event. Verify that your machine has been wired correctly. Refer to <b>Installation</b> , page 7.
	Controller output is incorrect	Confirm output voltage (Pump Output +) from controller during lubrication event is correct (should be similar to input voltage).  If controller output voltage is never present, the device may need replacement.
		Measure at controller to ensure there is not a wiring issue causing the problem.
Reservoir runs out of grease quickly and unexpectedly	TEST MODE is engaged	Turn off TEST MODE.
	There is a leak	Check reservoir and lines for leaks.
Always in low level	Review ground difference between the GLC X and the switch or sensor	Rewire if necessary.

# Accessories

Part Number	Description
26A882	GLC X Harness Kit
26A883	GLC X to CDS Harness Kit
26A884	CDS Harness Kit

# Dimensions

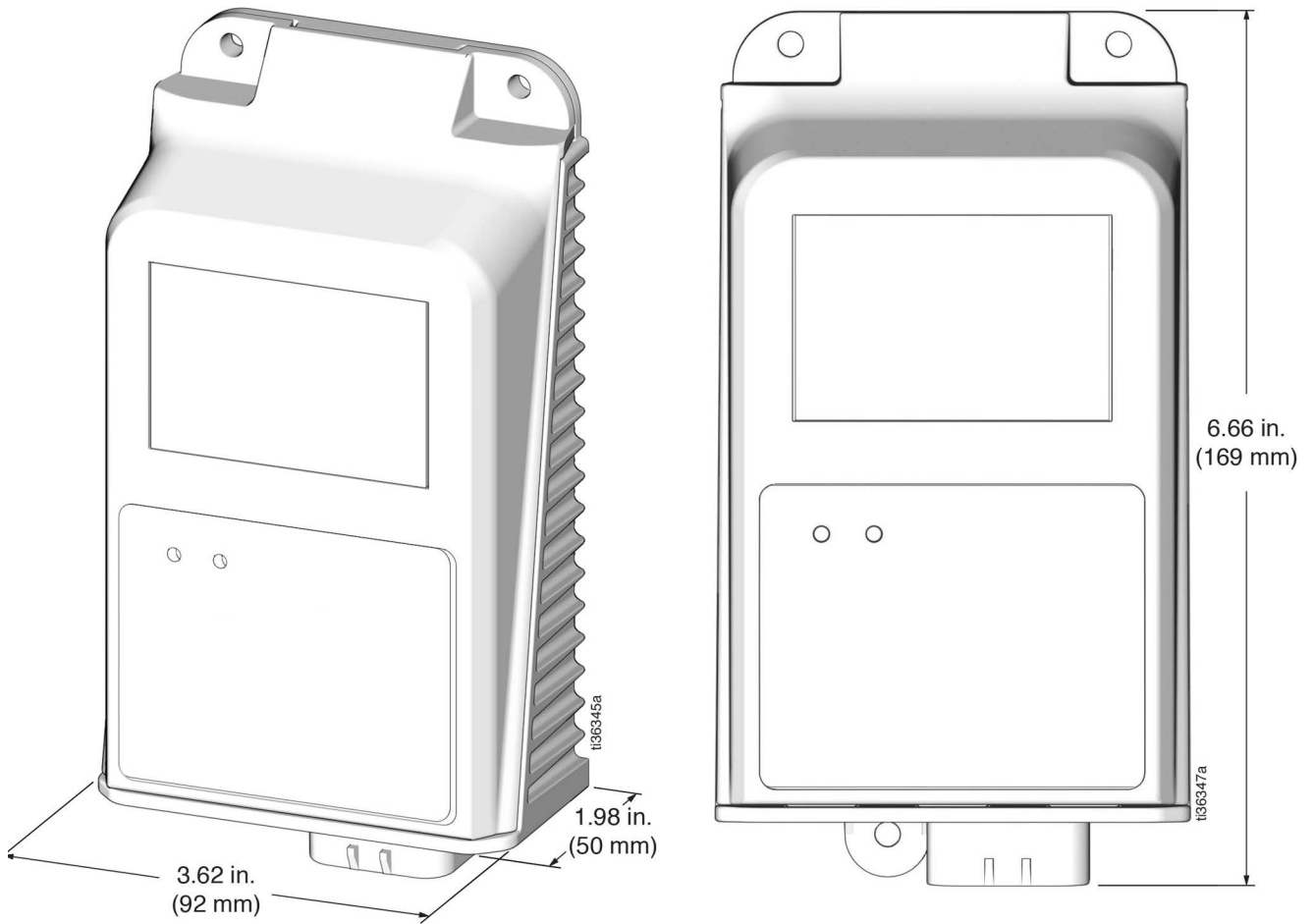

# Mounting Hole Layout

**NOTICE**

Pre-drill and use only designated mounting holes in Lubrication Controller box. Failure to use designated mounting holes can cause circuit board damage.

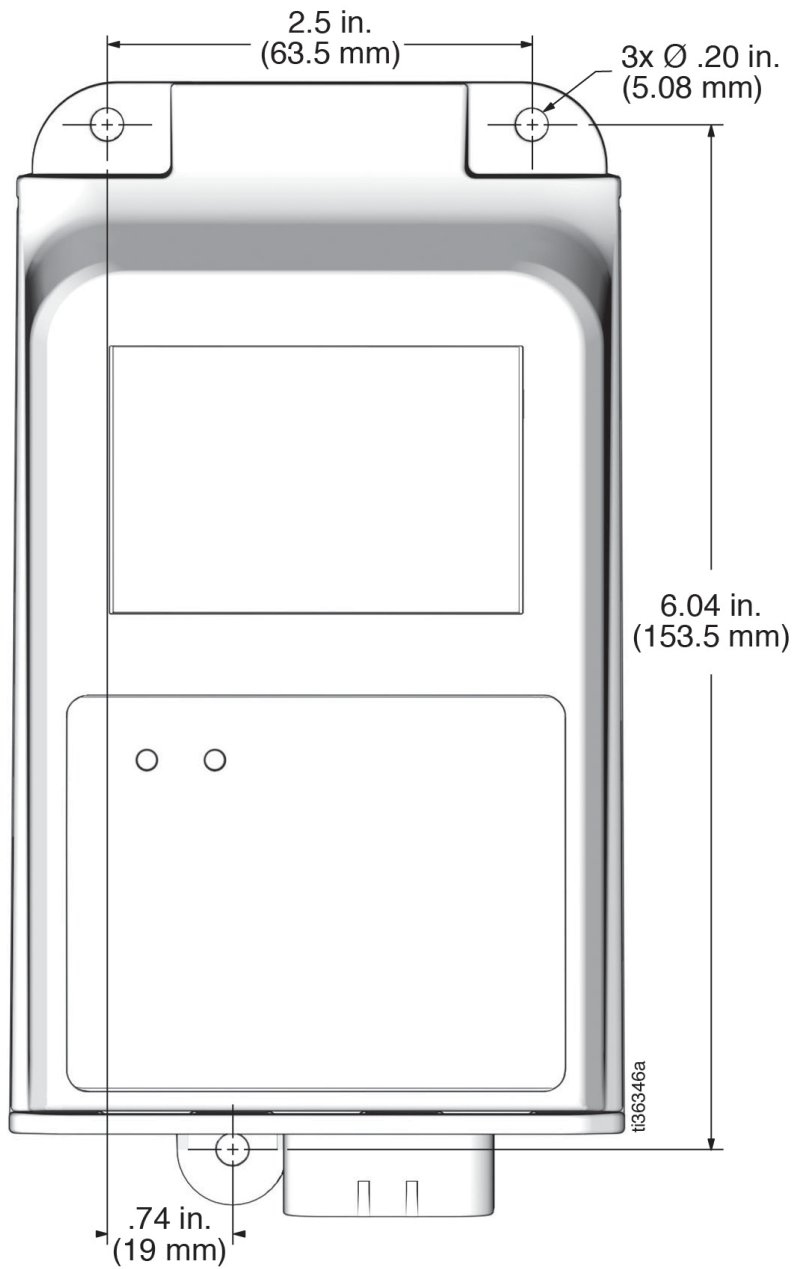



# Technical Specifications

<b>GLC X Controller</b>		
	<b>US</b>	<b>Metric</b>
<b>Climate</b>		
Operating Temperature Range	-22 F° to 158 F°	-30 C° to 70 C°
Storage Temperature	-22 F° to 158 F°	-30 C° to 70 C°
Maximum Humidity	90% RH (non-condensing)	
<b>Materials of Constructions</b>		
Enclosure Material	ABS	
Membrane Material	Polyester	
Lens Material	Polycarbonate	
<b>Input Contact</b>		
Power Source DC	9 - 30 VDC	
Power Consumption	1 W (no load), 15 A (max)	
<b>Outputs*</b>		
Pump Control		
Max Switching Voltage	30 VDC	
Max Switching Current	10 A	
Auxiliary		
Max Switching Voltage	30 VDC	
Max Switching Current	10 A	
<b>Inputs 1 and 2</b>		
Maximum Analog Voltage Input	10 V	
<b>Inputs 3 and 4</b>		
Maximum input rate	300 rpm	
<b>Noise (dBa)</b>		
Maximum sound pressure	Less than 70 dB	
<b>Miscellaneous Data</b>		
IP Rating	IP69K	
Bluetooth LE	1 mW	
Altitude	<2000m	

All trademarks or registered trademarks are the property of their respective owners.

Apple and the Apple App Store are registered trademarks of Apple Inc.

Google Play and the Google Play logo are trademarks of Google LLC.

\*Total current from all outputs maximum is 15 A.

# Compliance

## Radio Frequency Approvals

Transmitter Frequency: 2.4 GHz  
Transmitter Power: +0 dBm

**NOTE:** FCC/IC Notice (all models)  
Contains FCC ID: A8TBM7152  
Contains IC: 12246A-BM7152

The enclosed device complies with Part 15 of the FCC Rules and with the Industry Canada license-exempt RSS standard(s). Operation is subject to the following two conditions: (1) this device may not cause harmful interference and (2) this device must accept any interference received, including interference that may cause undesired operation.

Changes or modifications not expressly approved by the party responsible for compliance could void the user's authority to operate the equipment.

This equipment is not granted protection against harmful interference and cannot cause interference on systems property authorized.

	
 <p>Este equipamento não tem direito à proteção contra interferência prejudicial e não pode causar interferência em sistemas devidamente autorizados.</p> <p>Para maiores informações consultar: <a href="http://www.anatel.gov.br">www.anatel.gov.br</a></p>	
 R 005-101150	

## California Proposition 65

 **WARNING:** This product can expose you to chemicals known to the State of California to cause cancer and birth defects or other reproductive harm. For more information, go to [www.P65warnings.ca.gov](http://www.P65warnings.ca.gov).

# Graco Standard Warranty

Graco warrants all equipment referenced in this document which is manufactured by Graco and bearing its name to be free from defects in material and workmanship on the date of sale to the original purchaser for use. With the exception of any special, extended, or limited warranty published by Graco, Graco will, for a period of twelve months from the date of sale, repair or replace any part of the equipment determined by Graco to be defective. This warranty applies only when the equipment is installed, operated and maintained in accordance with Graco's written recommendations.

This warranty does not cover, and Graco shall not be liable for general wear and tear, or any malfunction, damage or wear caused by faulty installation, misapplication, abrasion, corrosion, inadequate or improper maintenance, negligence, accident, tampering, or substitution of non-Graco component parts. Nor shall Graco be liable for malfunction, damage or wear caused by the incompatibility of Graco equipment with structures, accessories, equipment or materials not supplied by Graco, or the improper design, manufacture, installation, operation or maintenance of structures, accessories, equipment or materials not supplied by Graco.

This warranty is conditioned upon the prepaid return of the equipment claimed to be defective to an authorized Graco distributor for verification of the claimed defect. If the claimed defect is verified, Graco will repair or replace free of charge any defective parts. The equipment will be returned to the original purchaser transportation prepaid. If inspection of the equipment does not disclose any defect in material or workmanship, repairs will be made at a reasonable charge, which charges may include the costs of parts, labor, and transportation.

**THIS WARRANTY IS EXCLUSIVE, AND IS IN LIEU OF ANY OTHER WARRANTIES, EXPRESS OR IMPLIED, INCLUDING BUT NOT LIMITED TO WARRANTY OF MERCHANTABILITY OR WARRANTY OF FITNESS FOR A PARTICULAR PURPOSE.**

Graco's sole obligation and buyer's sole remedy for any breach of warranty shall be as set forth above. The buyer agrees that no other remedy (including, but not limited to, incidental or consequential damages for lost profits, lost sales, injury to person or property, or any other incidental or consequential loss) shall be available. Any action for breach of warranty must be brought within two (2) years of the date of sale.

**GRACO MAKES NO WARRANTY, AND DISCLAIMS ALL IMPLIED WARRANTIES OF MERCHANTABILITY AND FITNESS FOR A PARTICULAR PURPOSE, IN CONNECTION WITH ACCESSORIES, EQUIPMENT, MATERIALS OR COMPONENTS SOLD BUT NOT MANUFACTURED BY GRACO.** These items sold, but not manufactured by Graco (such as electric motors, switches, hose, etc.), are subject to the warranty, if any, of their manufacturer. Graco will provide purchaser with reasonable assistance in making any claim for breach of these warranties.

In no event will Graco be liable for indirect, incidental, special or consequential damages resulting from Graco supplying equipment hereunder, or the furnishing, performance, or use of any products or other goods sold hereto, whether due to a breach of contract, breach of warranty, the negligence of Graco, or otherwise.

## **FOR GRACO CANADA CUSTOMERS**

The Parties acknowledge that they have required that the present document, as well as all documents, notices and legal proceedings entered into, given or instituted pursuant hereto or relating directly or indirectly hereto, be drawn up in English. Les parties reconnaissent avoir convenu que la rédaction du présente document sera en Anglais, ainsi que tous documents, avis et procédures judiciaires exécutés, donnés ou intentés, à la suite de ou en rapport, directement ou indirectement, avec les procédures concernées.

# Graco Information

For the latest information about Graco products, visit [www.graco.com](http://www.graco.com).

For patent information, see [www.graco.com/patents](http://www.graco.com/patents).

**TO PLACE AN ORDER**, contact your Graco distributor or call to identify the nearest distributor.

**Phone:** 612-623-6928 or **Toll Free:** 1-800-533-9655, **Fax:** 612-378-3590

*All written and visual data contained in this document reflects the latest product information available at the time of publication. Graco reserves the right to make changes at any time without notice.*

Original instructions. This manual contains English. MM 3A7031

**Graco Headquarters:** Minneapolis

**International Offices:** Belgium, China, Japan, Korea

**GRACO INC. AND SUBSIDIARIES • P.O. BOX 1441 • MINNEAPOLIS MN 55440-1441 • USA**  
**Copyright 2019, Graco Inc. All Graco manufacturing locations are registered to ISO 9001.**

[www.graco.com](http://www.graco.com)  
Revision D, July 2023