

GCI™ Series Injectors

3A9293F

EN

For single-line parallel automatic lubrication systems only. For professional use only.



Important Safety Instructions

Read all warnings and instructions in this manual before using the equipment. Save these instructions.

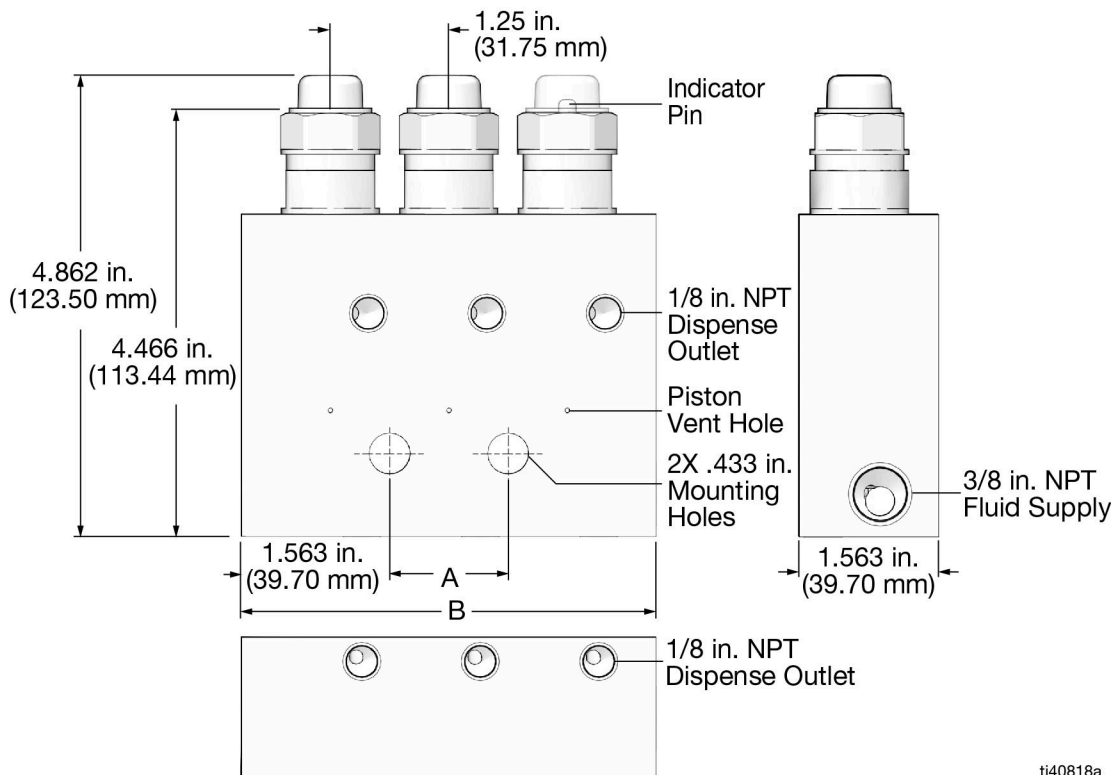

ti40818a







Models

NOTE: Cartridges and manifolds are sold separately.

| Description | Part No. | Pressure | Zerk and Cap Fittings Qty. | Distance Between Mounting Holes (A) | Manifold Length (B) |
|---------------------------------------|----------|---------------------------------|----------------------------|-------------------------------------|---------------------------|
| Standard Pressure Applications | | | | | |
| Manifold, 2 point | 134362 | 3500 psi (24.1 MPa, 241 bar) | 2 | | 3.125 in. (79.375 mm) |
| Manifold, 3 point | 134363 | 3500 psi (24.1 MPa, 241 bar) | 3 | 1.25 in. (31.75 mm) | 4.375 in. (111.125 mm) |
| Manifold, 4 point | 134364 | 3500 psi (24.1 MPa, 241 bar) | 4 | 2.50 in. (63.4 mm) | 5.625 in. (142.875 mm) |
| Manifold, 5 point | 134365 | 3500 psi (24.1 MPa, 241 bar) | 5 | 3.75 in. (95.1 mm) | 6.875 in. (174.625 mm) |
| Manifold, 6 point | 134366 | 3500 psi (24.1 MPa, 241 bar) | 6 | 4.99 in. (126.8 mm) | 8.125 in. (206.375 mm) |
| High Pressure Applications | | | | | |
| Manifold, 2 point | 134372 | 5000 psi (34.5 MPa, 345 bar) | 2 | | 3.125 in. (79.375 mm) |
| Manifold, 3 point | 134373 | 5000 psi (34.5 MPa, 345 bar) | 3 | 1.25 in. (31.75 mm) | 4.375 in. (111.125 mm) |
| Manifold, 4 point | 134374 | 5000 psi (34.5 MPa, 345 bar) | 4 | 2.50 in. (63.4 mm) | 5.625 in. (142.875 mm) |
| Manifold, 5 point | 134375 | 5000 psi (34.5 MPa, 345 bar) | 5 | 3.75 in. (95.1 mm) | 6.875 in. (174.625 mm) |
| Manifold, 6 point | 134376 | 5000 psi (34.5 MPa, 345 bar) | 6 | 4.99 in. (126.8 mm) | 8.125 in. (206.375 mm) |
| GCI 150 Cartridges | | | | | |
| Single | 134250 | 5000 psi (34.5 MPa, 345 bar) | | | |
| 100 pack | 134354 | 5000 psi (34.5 MPa, 345 bar) | | | |

Warnings

The following warnings are for the setup, use, grounding, maintenance, and repair of this equipment. The exclamation point symbol alerts you to a general warning and the hazard symbols refer to procedure-specific risks. When these symbols appear in the body of this manual or on warning labels, refer back to these Warnings. Product-specific hazard symbols and warnings not covered in this section may appear throughout the body of this manual where applicable.

|  WARNING | |
|---|---|
| <div style="display: flex; flex-direction: column; gap: 10px;">      </div> | <p>SKIN INJECTION HAZARD</p> <p>High-pressure fluid from dispensing device, hose leaks, or ruptured components will pierce skin. This may look like just a cut, but it is a serious injury that can result in amputation. Get immediate surgical treatment.</p> <ul style="list-style-type: none"> Do not point dispensing device at anyone or at any part of the body. Do not put your hand over the fluid outlet. Do not stop or deflect leaks with your hand, body, glove, or rag. Follow the Pressure Relief Procedure when you stop dispensing and before cleaning, checking, or servicing equipment. Tighten all fluid connections before operating the equipment. Check hoses and couplings daily. Replace worn or damaged parts immediately. |
|  | <p>PERSONAL PROTECTIVE EQUIPMENT</p> <p>Wear appropriate protective equipment when in the work area to help prevent serious injury, including eye injury, hearing loss, inhalation of toxic fumes, and burns. Protective equipment includes but is not limited to:</p> <ul style="list-style-type: none"> Protective eyewear, and hearing protection. Respirators, protective clothing, and gloves as recommended by the fluid and solvent manufacturer. |

Installation



NOTES:

- Group the injectors to minimize the feed line length.
- Install injectors in locations that allow easy and safe service access.
- Install injectors in areas that minimize accidental injector damage by movement of the equipment.
- Injector outputs can be combined for a common bearing point with a large grease requirement, but the output for a single injector cannot be split into multiple bearing points.
- Steel tubing is recommended instead of pipe and hose for supply lines, when possible.
 - Pipe is often contaminated with scale and requires proper cleaning prior to use.
 - Hose expands under pressure leading to longer pump cycle time.



SKIN INJECTION HAZARD

The equipment may be pressurized already, or it could become pressurized by an automatic lube cycle initiated by Lubrication Controller (timer). Disconnect power to the timer and disconnect the air supply to the pump module to ensure that the system is depressurized. **See the pressure relief procedure in the pump manual included with your automatic lubrication system.**

1. Relieve system pressure. Follow the pressure relief procedure in the pump instruction manual included with your automatic lubrication system.
2. Apply thread sealant (supplied with each manifold) to the external threads of the output spacers (3).

NOTE: Do not apply thread sealant to internal spacer threads or cartridge (2) threads.

3. Install output spacers (3) at each manifold port. Choose a spacer color to match the desired output, (See **Output Spacer Kits**, page 7) (FIG. 1) and torque spacers to 60 ft-lb (81.3 N•m).

NOTICE

Use 6-point socket to torque or loosen spacers. An open ended wrench can damage the spacers.

4. Lubricate the external cartridge seals then install the cartridges (2), see FIG. 1, and torque to 40 ft-lb (54.2 N•m).

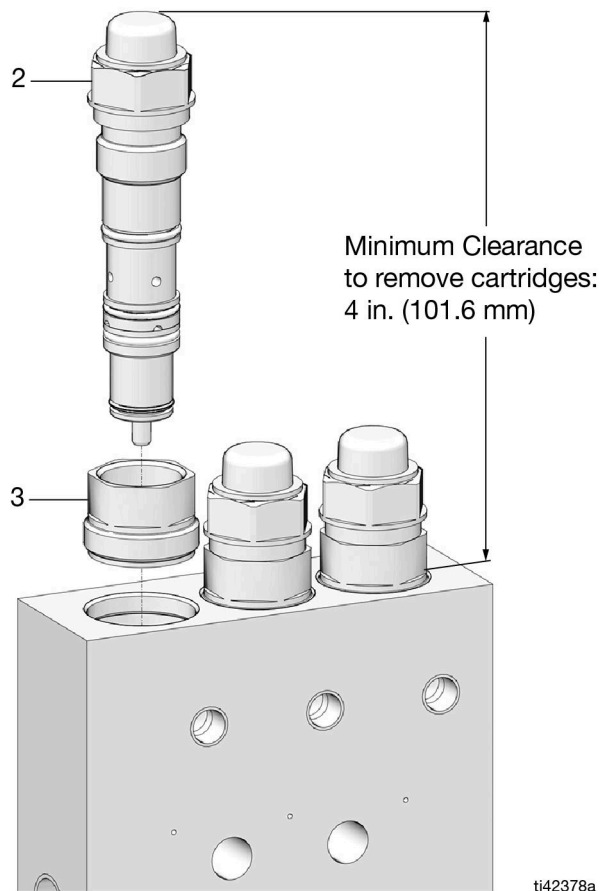

FIG. 1

5. Install the feed line fittings into one of the two dispense outlet ports for each injector.
6. Install a zerk and cap fitting into the unused dispense outlet port for each injector.
7. Install the main fluid supply line fittings to the fluid supply ports on the manifold (FIG. 2).

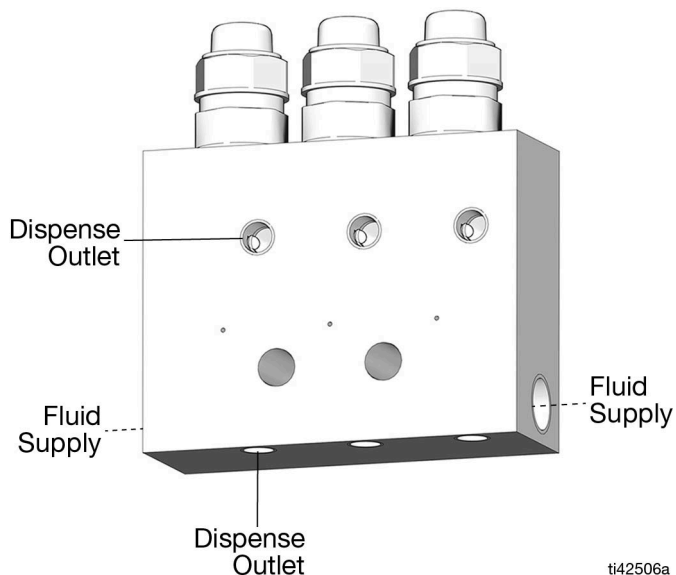

FIG. 2

8. Install the injectors on a flat, hard surface. The injectors can be installed in a variety of ways: mounting brackets, weld studs, and tapped holes are a few examples.
9. Purge the main fluid supply line of air and contaminants: run the pump until clean lubricant is dispensed from the end of each main line.
10. Connect the main fluid supply line to the manifold (FIG. 3).

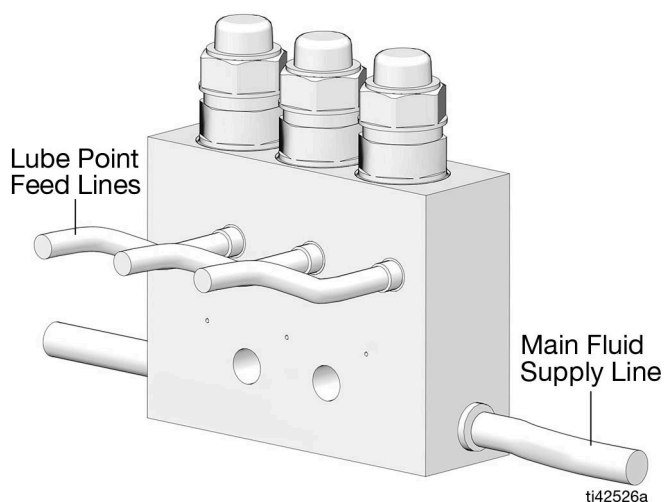

FIG. 3

11. Run the system to verify that all of the injectors cycle and dispense grease.

NOTE: When the system pressure is high enough to activate the injectors, the minimum travel groove is shown during the lube cycle (FIG. 4). If this does not happen, increase the system pressure.

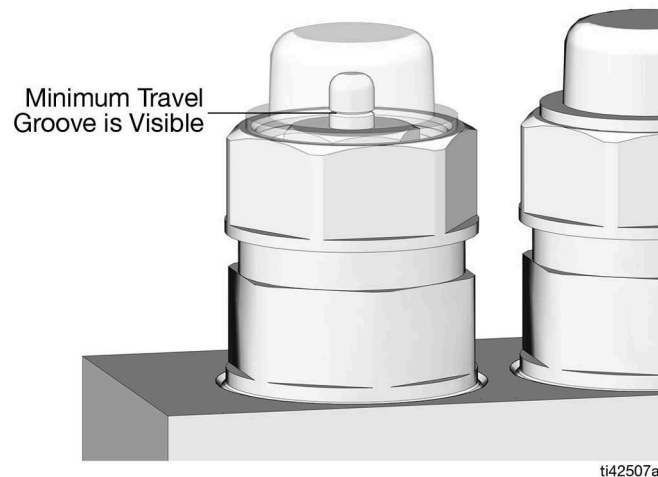

FIG. 4

NOTE: It may take several lube cycles to purge the air from the injectors and for grease to start dispensing.

12. Connect the lube point feed lines to the manifold (FIG. 3).Purge the lube point feed lines of air and contaminants: pump grease through the zerk and cap fittings connected to each injector fluid outlet until clean lubricant is dispensed at the end of each lube point feed line.
13. Attach the lube point feed lines to the lubrication points.

Maintenance

Replace Cartridge Injector

There are no repair kits for the cartridge. See **Models**, page 2 for replacement cartridge part numbers.



1. Run a lube cycle to reduce seal friction on the cartridge.
2. Relieve pressure. Follow the pressure relief procedure in the pump instruction manual included with your automatic lubrication system.
3. Remove cartridge (2) from the manifold (FIG. 5).
4. Install the new cartridge and torque to 40 ft-lb (54.2 N•m).

Dispense Volume Adjustment



See **Available Kits**, page 7, for dispense output target information.

1. Run a lube cycle to reduce seal friction on the cartridge.
2. Relieve pressure. Follow the pressure relief procedure in the pump instruction manual included with your automatic lubrication system.
3. Remove cartridge (2) and the existing output spacer (3) from the manifold (FIG. 5).

NOTICE

Use 6-point socket to torque or loosen spacers. An open ended wrench can damage the spacers.

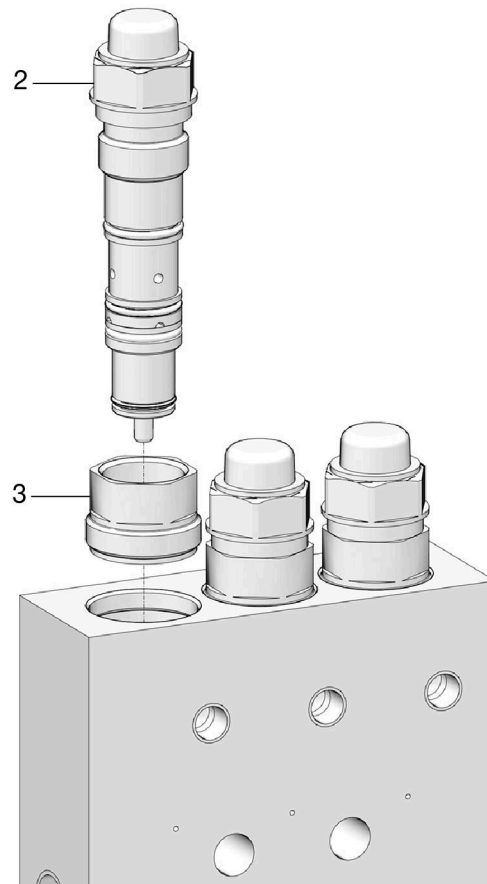

ti42411a

FIG. 5

4. Insert color-coded output spacer for desired output (see Spacer Kit Table, page 6) and torque to 60 ft-lb (81.3 N•m) (FIG. 6).

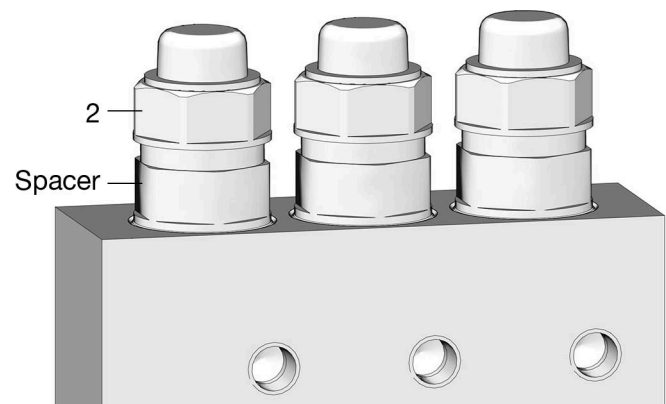

ti40820a

FIG. 6

5. Install cartridge and torque to 40 ft-lb (54.2 N•m).

Available Kits

Use only genuine Graco parts.

Output Spacer Kits

| P/N | Color | Output Target | |
|--------|--------|------------------|------|
| | | in. ³ | cc |
| 134337 | Black | 0.015 | 0.25 |
| 134338 | Red | 0.030 | 0.49 |
| 134339 | Silver | 0.045 | 0.74 |
| 134340 | Gold | 0.060 | 0.98 |
| 134341 | Green | 0.080 | 1.31 |
| 134342 | Grey | 0.100 | 1.64 |
| 134343 | Purple | 0.125 | 2.05 |
| 134344 | Blue | 0.150 | 2.46 |

Crossover Kit (P/N 134105): connects the outlets of the injectors for increased output.

Injector Port Plug (P/N 133668): plugs the unused port in the manifold.

Zerk and Cap Fitting (P/N 114916): plugs the unused dispense outlet port.

Dust Cap Replacement (P/N 134393): clear replacement cover for the indicator pin.

Recycle and Disposal

End of Product Life

At the end of the product's useful life, recycle it in a responsible manner.

Troubleshooting



Follow **Pressure Relief Procedure** in the pump instruction manual, included with your automatic lubrication system, before checking or repairing the injectors.

| Problem | Cause | Solution |
|--|--|--|
| Grease not reaching the dispense point | Pressure setting is too low | Increase the pump pressure |
| | Blocked line | Clear the line blockage |
| | Cartridge injector is seized | Replace the cartridge injector |
| Indicator pin not moving up | Pressure setting is too low | Increase the pump pressure |
| | Cartridge injector is seized | Replace the cartridge injector |
| Excessive piston vent hole leakage | Failed dynamic seals in cartridge injector | Replace the cartridge injector |
| Excessive grease at dispense point | Output spacer is too large | Replace the output spacer with a smaller output size |
| | Cartridge fluid bypass due to worn out seals | Replace the cartridge injector |

Technical Specifications

| GCI Series Injectors | | |
|--|--|--------------------|
| | US | Metric |
| Maximum operating pressure | | |
| Standard pressure manifolds (aluminum) | 3500 psi | 24.1 MPa, 241 bar |
| High pressure manifolds (steel) | 5000 psi | 34.5 MPa, 345 bar |
| GCI 150 cartridges | 5000 psi | 34.5 MPa, 345 bar |
| Suggested operating pressure | 2500 psi | 17 MPa, 172 bar |
| Reset pressure | 1000 psi | 6.89 MPa, 68.9 bar |
| Output volume per cycle | 0.015 to 0.150 in. ³ | 0.25 to 2.46 cc |
| Recommended fluids | N.L.G.I. #2 grease down to 32°F (0°C) | |
| Materials of Construction | | |
| Wetted materials on all models | Carbon steel, nitrile rubber, aluminum | |

California Proposition 65

CALIFORNIA RESIDENTS

 **WARNING:** Cancer and reproductive harm – www.P65warnings.ca.gov.

Graco GCI™ Series Injectors Warranty

Graco warrants all equipment referenced in this document which is manufactured by Graco and bearing its name to be free from defects in material and workmanship on the date of sale to the original purchaser for use. With the exception of any special, extended, or limited warranty published by Graco, Graco will, for a period of twenty-four months from the date of sale or up to 100,000 lube cycles, whichever ever comes first, repair or replace any part of the equipment determined by Graco to be defective. This warranty applies only when the equipment is installed, operated and maintained in accordance with Graco's written recommendations.

This warranty does not cover, and Graco shall not be liable for general wear and tear, or any malfunction, damage or wear caused by faulty installation, use of grease with solid lubricants, contaminated grease, misapplication, abrasion, corrosion, inadequate or improper maintenance, negligence, accident, tampering, or substitution of non-Graco component parts. Nor shall Graco be liable for malfunction, damage or wear caused by the incompatibility of Graco equipment with structures, accessories, equipment or materials not supplied by Graco, or the improper design, manufacture, installation, operation or maintenance of structures, accessories, equipment or materials not supplied by Graco.

This warranty is conditioned upon the prepaid return of the equipment claimed to be defective to an authorized Graco distributor for verification of the claimed defect. If the claimed defect is verified, Graco will repair or replace free of charge any defective parts. The equipment will be returned to the original purchaser transportation prepaid. If inspection of the equipment does not disclose any defect in material or workmanship, repairs will be made at a reasonable charge, which charges may include the costs of parts, labor, and transportation.

THIS WARRANTY IS EXCLUSIVE, AND IS IN LIEU OF ANY OTHER WARRANTIES, EXPRESS OR IMPLIED, INCLUDING BUT NOT LIMITED TO WARRANTY OF MERCHANTABILITY OR WARRANTY OF FITNESS FOR A PARTICULAR PURPOSE.

Graco's sole obligation and buyer's sole remedy for any breach of warranty shall be as set forth above. The buyer agrees that no other remedy (including, but not limited to, incidental or consequential damages for lost profits, lost sales, injury to person or property, or any other incidental or consequential loss) shall be available. Any action for breach of warranty must be brought within two (2) years of the date of sale.

GRACO MAKES NO WARRANTY, AND DISCLAIMS ALL IMPLIED WARRANTIES OF MERCHANTABILITY AND FITNESS FOR A PARTICULAR PURPOSE, IN CONNECTION WITH ACCESSORIES, EQUIPMENT, MATERIALS OR COMPONENTS SOLD BUT NOT MANUFACTURED BY GRACO. These items sold, but not manufactured by Graco (such as electric motors, switches, hose, etc.), are subject to the warranty, if any, of their manufacturer. Graco will provide purchaser with reasonable assistance in making any claim for breach of these warranties.

In no event will Graco be liable for indirect, incidental, special or consequential damages resulting from Graco supplying equipment hereunder, or the furnishing, performance, or use of any products or other goods sold hereto, whether due to a breach of contract, breach of warranty, the negligence of Graco, or otherwise.

FOR GRACO CANADA CUSTOMERS

The Parties acknowledge that they have required that the present document, as well as all documents, notices and legal proceedings entered into, given or instituted pursuant hereto or relating directly or indirectly hereto, be drawn up in English. Les parties reconnaissent avoir convenu que la rédaction du présente document sera en Anglais, ainsi que tous documents, avis et procédures judiciaires exécutés, donnés ou intentés, à la suite de ou en rapport, directement ou indirectement, avec les procédures concernées.

Graco Information

For the latest information about Graco products, visit www.graco.com.

For patent information, see www.graco.com/patents.

TO PLACE AN ORDER, contact your Graco distributor or call to identify the nearest distributor.

Phone: 612-623-6928 **or Toll Free:** 1-800-533-9655, **Fax:** 612-378-3590

All written and visual data contained in this document reflects the latest product information available at the time of publication. Graco reserves the right to make changes at any time without notice.

Original instructions. This manual contains English. MM 3A9293

Graco Headquarters: Minneapolis

International Offices: Belgium, China, Japan, Korea

GRACO INC. AND SUBSIDIARIES • P.O. BOX 1441 • MINNEAPOLIS MN 55440-1441 • USA
Copyright 2023, Graco Inc. All Graco manufacturing locations are registered to ISO 9001.

www.graco.com
Revision F, February 2024